STANDARD SANITARY SEWER REQUIREMENTS

PREPARED FOR:



Town of North Smithfield

P.O. Box 248

Slatersville, RI 02876

PREPARED BY:



JAMES J. GEREMIA & ASSOCIATES, INC.

272 WEST EXCHANGE STREET, SUITE 201

PROVIDENCE, RHODE ISLAND 02903-1061

ADOPTED BY: SEWER COMMISSION

JANUARY 21, 2009

ADOPTED BY: TOWN COUNCIL

FEBRUARY 2, 2009

TABLE OF CONTENTS

	<u>PAGE</u>
SECTION I – GENERAL SANITARY SEWER REQUIREMENTS	
• General Requirements.....	1-1
• Drainlayer Requirements.....	1-1
• Privately-Owned Wastewater Treatment Facilities.....	1-2
• Sewer Extensions.....	1-4
• Drawings.....	1-4
• As-Built / Record Drawings.....	1-4
• Qualifications of Material and Equipment.....	1-5
• Sanitary Sewer Information Required.....	1-6
• Sewer Construction Requirements.....	1-6
SECTION II – SPECIFICATIONS	
• Sanitary Sewage System.....	2-1
• Sanitary Sewage Service Connections.....	2-14
• Low Pressure Sewer Grinder Pump Stations.....	2-20
• Bituminous Paving.....	2-23
• Bituminous Concrete Walks.....	2-28
• Cement Concrete Walks.....	2-30
SECTION III – DETAILS	
• NS-1 Trench Detail	
• NS-2 Trench Details Wet Conditions	
• NS-3 Sewer Manhole Detail	
• NS-4 Precast Manhole Detail	
• NS-5 Bolted & Gasketed Frame & Cover	
• NS-6 Sanitary Shallow Manhole Detail	
• NS-7 Inside Drop Sanitary Manhole	
• NS-8 External Drop Sanitary Manhole	
• NS-9 Sanitary Manhole Frame & Cover	
• NS-10 Standard House Connection Detail	
• NS-11 Standard Deep House Connection	
• NS-12 Thrust Blocks	
• NS-13 Low Pressure Sewer Trench	
• NS-14 Low Pressure Sewer Inside Drop Manhole	
• NS-15 Low Pressure Sewer Service Connection	
• NS-16 Low Pressure Terminal End Flushing Connection	
• NS-17 Low Pressure In-Line Straight Through Flushing Connection	
• NS-18 Low Pressure In-Line With Side Connection Flushing Connection	
• NS-19 By-Pass Pumping Connection at Pump Station	

SECTION I
GENERAL SANITARY SEWER REQUIREMENTS

GENERAL SANITARY SEWER REQUIREMENTS

1. PART 1 – GENERAL

1.1 GENERAL REQUIREMENTS:

- A. All requirements of the **North Smithfield Sewer Ordinance** including the **Standard Sanitary Sewer Requirements** set forth herein and the regulations of the North Smithfield Sewer Department (NSSD) shall be adhered to.
- B. Plans, specifications, and design calculations for proposed sanitary sewage system(s) except for sanitary service connections shall be submitted to the Sewer Superintendent for review. Design calculations shall conform to the Department of Environmental Management requirements.
- C. Plans, specifications, and calculations for sanitary sewage system extensions shall be prepared and stamped by an Engineer currently registered in the State of Rhode Island.
- D. An Order of Approval shall be obtained from the Department of Environmental Management when applicable.

1.2 DRAINLAYER REQUIREMENTS:

- A. General:
 - 1. The licensed Drainlayer or Master Plumber shall perform his or her work in the Town of North Smithfield in accordance with all applicable sections of the North Smithfield Town Ordinance, North Smithfield Sewer Ordinance and the Standard Sanitary Sewer Requirements.
 - 2. The licensed Drainlayer or Master Plumber shall comply with the requirements of the Town's Drainlayers License Application.
 - 3. Licenses for Drainlayers shall expire on the first day of December of each year following date of issuance.
- B. An accurate record of all Drainlayer's licenses shall be kept both at the Superintendent's office and the office of the Town Clerk. Notice must be given to the Superintendent at least 48 hours prior to the beginning of any work on a sewer. No inspections will be scheduled until the permit application has been duly signed and returned to the Town. All sewer permits shall be posted in a visible manner at the site of any and all sewer work. Such information as the Town has with regard to the existence or location of main or building sewers will be furnished to the Drainlayers upon request, but at their risk as to the accuracy of the information. No materials shall be used or work covered until inspected and approved by the Superintendent or his designee, and the Drainlayer's return portion of each building sewer connection permit shall be promptly returned to the Superintendent

after the work has been thoroughly inspected and the return as been signed by the inspecting authority.

- C. Failure to comply with any provisions of this article by the Drainlayer or Master Plumber may result in the forfeiture of the right, as determined by the Superintendent, or his designee, to perform building or main sewer work within the Town. The Town also reserves the right to withhold the issuance of any sewer permits to any Drainlayer or Master Plumber found in violation of any provisions of this article.

1.3 PRIVATELY-OWNED WASTEWATER TREATMENT FACILITIES:

- A. Privately-owned and operated pump stations and collection systems connected to the North Smithfield Wastewater System must adhere to the Standard Sanitary Sewer Requirements. In addition, the owner must submit, for the Sewer Commission's approval, the following.
 - 1. Owners of Privately-Owned Wastewater Treatment Facilities shall maintain the system in good working order and operate as efficiently as possible. Proper operation and maintenance shall include, but not be limited to, effective performance based on facility design, adequate operator staffing and training, and adequate laboratory and process controls, including quality assurance procedures as determined to be appropriate by the Commission and backup or auxiliary facilities or similar systems to assure compliance or effective performance. Proper operation and maintenance must include emergency procedures and reporting requirements in case of power outages, natural disaster, labor shortage (whether the result of intentional work stoppages or epidemic), equipment failure, acts of terrorism/vandalism or sanitary sewer overflow. Reporting requirements shall include verbal notification to the Superintendent of Sewers and the Rhode Island Department of Environmental Management (RIDEM) as soon as possible, but not exceeding twenty-four (24) hours of discovery of the event; a written report must be submitted to the Superintendent of Sewers and RIDEM not more than five (5) business days of the event's ending.
 - 2. The owner shall submit, for review and approval by the Superintendent of Sewers, an Operations and Maintenance Manual describing standards and procedures by which the Wastewater Treatment Facilities, pump station(s) and/or collection system(s) will be staffed, operated and maintained during normal and emergency conditions. Should development of the Plan include the practice of engineering, the Plan must then be prepared and certified by a Registered Professional Engineer registered in the State of Rhode Island. The Operations and Maintenance Plan must be approved prior to commencement of the construction of the new Wastewater Treatment Facility.
 - 3. The owner shall pay an annual Permit Fee for the operation of the facilities. The fee shall be adopted by the Town annually.

4. The owner is required to conduct (at a minimum) monthly inspections of the pump station. The inspection reports shall be forwarded to the Superintendent of Sewers within three (3) business days after the inspection. At a minimum, the inspection report shall provide the name of the individual or firm performing the inspection, hours of operation for each pump, generator run time, summary of alarms, any maintenance undertaken during that month, condition of the station, and recommendations.

5. The Operations and Maintenance Plan shall include, but not be limited to, the following elements:
 - a. Describe the detailed operating procedures for the pump station(s) and collection system;
 - b. Provide a Preventative Maintenance Plan for the pump station;
 - c. Provide staffing requirements;
 - d. Provide a list of material suppliers and essential spare parts necessary to be kept on site for normal and emergency conditions;
 - e. Provide operating procedures for the emergency generator and automatic transfer switch;
 - f. Provide a Spill Prevention Plan;
 - g. Provide a description of the auxiliary system, such as water, heating and ventilation, sump pump and dehumidifying;
 - h. Provide a description of the alarm system and response procedures;
 - i. Provide names, addresses and telephone numbers of all emergency contacts, facility owners and facility operators;
 - j. Provide a list of subcontractors that are on call for emergency equipment rental (i.e., septage hauler, portable pump or generator).
 - k. Provide emergency procedures and reporting requirements in case of power outages, natural disasters, equipment failure, acts of vandalism, or sanitary sewer overflow;
 - l. Provide a description of the means of recordkeeping (the records must be accessible for a three (3) year period);
 - m. Provide as-built plans for the pump station and/or collection system;

- n. Provide a sewer map of the collection system, including but not limited to, the overall service area, diameter of pipes, distance between manholes, slope and direction of flow; and
- o. Provide all required easements that will allow the Town of North Smithfield access to the site for unannounced periodic inspections

1.4 SEWER EXTENSIONS:

- A. Sewer extensions will be allowed only if the receiving interceptors and pumping stations are capable of adequately processing the added hydraulic load. Documentation assessing the existing interceptor(s) and pumping station(s) shall be submitted to the NSSD. The documentation shall be stamped by a professional engineer registered in the State of Rhode Island.
- B. The proposed sewer extension must be consistent with the most recent Wastewater Management Facilities Plan adopted by the Town and the Rhode Island Department of Environmental Management.

1.5 DRAWINGS:

- A. The applicant must furnish drawings showing the location of the premises together with the location of all underground piping, proposed connection points, applicable details, general notes, utility conflict corrections, and other appurtenances to be installed on the premises at the time of making the application.
- B. Drawings shall be submitted on a maximum size of 24" by 36" prints. Two (2) sets shall be submitted at the initial submission for indication of comments during the review stage. If a project is to be implemented in stages or phases, a master plan showing the entire site development, including all future expansion areas, shall be submitted for review during the first submission.
- C. Drawings shall not be at a scale less than 1-inch per 40-feet and no more than 1-inch per 20-feet.
- D. All site plans shall contain contours at a minimum of 2-foot intervals based on National Geodetic Vertical Datum (N.G.V.D.) and not with assumed elevations. Site plans shall include a locus map at a scale of not less than 1-inch = 2,000 feet and a north arrow.
- E. All drawings are to be signed and wet-stamped by a registered, professional engineer licensed in the State of Rhode Island under whose direction the design has been designed.

1.6 AS-BUILT / RECORD DRAWINGS:

- A. Upon completion of the project, the developer/owner shall provide preliminary as-built drawings documenting the record of actual construction. The preliminary as-built drawings

shall be on 24" x 36" sheets (plan scale 1" = 40') for review prior to acceptance of the new construction infrastructure.

- B. The developer/owner shall provide revised as-built drawings reflecting measurements from the building foundations and above-grade permanent structures and/or visible accessible permanent features. The final as-built drawing(s) set shall accurately mark the location of each infrastructure component or appurtenance as constructed including, but not limited to:
 - 1. Measured horizontal and vertical locations of the above and below grade sewer main, sewer services and appurtenances referenced to permanent surface improvements, above grade permanent structures and/or permanent visible and accessible features of the installation.
 - 2. Information concurrent with the actual construction.
 - 3. Three point measured swing ties from permanent surface improvements, above grade permanent structures and/or visible and accessible features of the installation to identify all bends, services and end caps.
 - 4. Depth of main at maximum of 50-foot intervals. Ties at every 100-foot interval, each recorded service and at each bend.
 - 5. Total overall footage.
 - 6. Detail of sewer service connection to the main.
- C. Upon approval of the "blue line" submission, a 6 mil. double-matte mylar media and print of the final "as-built" record drawing(s) shall be submitted and will remain the property of the Sewer Commission upon its approval and acceptance.
- D. Upon final approval, the contractor shall also provide the "as-built" in AutoCAD (latest edition) digital format acceptable to the Sewer Commission.

1.7 QUALIFICATIONS OF MATERIAL AND EQUIPMENT

- A. Specific manufacturers' names and catalog numbers are used herein to establish quality and design of a particular item.
- B. Wherever in the Specifications any item of equipment or material is designated by reference to a particular brand, manufacturer, or trade name, it is understood that a reviewed equal product, acceptable to the NSSD, may be submitted by the Contractor.
- C. If the Contractor proposes to use a material which, while suitable for the intended use, deviates in any way from the detailed requirements, he shall inform the NSSD in writing of the nature of such deviations at the time the material is submitted for review, and shall request a review of the deviation from the requirements.

- D. In requesting a review of deviations or substitutions, the Contractor shall provide evidence leading to a reasonable certainty that the proposed substitution or deviation shall provide a result at least equal in quality to that specified. If, in the opinion of the NSSD, the evidence presented by the Contractor does not provide a sufficient basis for such reasonable certainty, the NSSD will reject such substitution or deviation without further investigation, in which case it shall be the responsibility of the Contractor to provide another product which is satisfactory to the NSSD.

2. PART 2 - PRODUCTS

2.1 SANITARY SEWER INFORMATION REQUIRED:

- A. All vertical and horizontal alignment (profile and plan).
- B. Size, slopes, and materials to be used.
- C. Invert and rim elevations.
- D. Location and details of manholes.
- E. Other existing and proposed utilities should be shown in order to avoid conflicts during construction.
- F. Design sanitary flow calculations with Professional Engineer's stamp, except for sanitary service connections. Calculations shall conform to the Department of Environmental Management (DEM) requirements.

3. PART 3 - EXECUTION

3.1 SEWER CONSTRUCTION REQUIREMENTS:

- A. General Requirements: Sanitary sewer improvements shall conform to the requirements of the North Smithfield Sewer Department, Department of Environmental Management, and any other agencies having jurisdiction.
- B. Sanitary Sewers:
 - 1. Depth: Sewers shall be designed deep enough to drain basement fixtures and to prevent freezing. The minimum depth of cover for street installation shall be 6-feet and for cross country installation it shall be 4-feet.
 - 2. Slope: The following minimum slopes may be used only if necessary because of grade restrictions.
 - a. Sewer Size - Minimum Slope

<u>Inches</u>	<u>Feet/Foot</u>
8	0.0040
10	0.0028
12	0.0022
14	0.0017
15	0.0015
16	0.0014
18	0.0012
21	0.0010
24	0.0008
27	0.0007
30	0.0006
36	0.0005

3. Velocity: The minimum velocity for design purposes is 2-feet per second and the maximum velocity is 10-feet per second.
4. Alignment: Sewers shall be laid with a straight alignment between manholes.
5. Increasing Pipe Size: When a smaller sewer joins one of a larger one, the invert of the larger sewer should be lowered sufficiently to maintain the same hydraulic gradient.
6. Materials: Sewers shall be constructed of materials described in Section II. Sewers crossing streams or any body of water shall be ductile iron encased in concrete.
7. Manhole Locations: Manholes shall be installed at the end of each sewer line, at changes in grade, size, or alignment and at all intersections. The maximum spacing of manholes shall not exceed 300-feet.
8. Drop Manhole Type: A drop pipe should be provided for a sewer entering a manhole at an elevation of 24-inches or more above the manhole invert. The size of the drop pipe will be the same size as the sewer inlet pipe. Where the difference in elevation between the incoming sewer and the manhole invert is less than 24-inches, the invert shall be so constructed so that there is a smooth transition of flow in the manhole.
9. Manhole Diameter: The minimum internal diameter of manhole shall be 48-inches and internal drop manholes shall have a minimum internal diameter of 60-inches.
10. Flow Channel: A drop of at least 0.1-feet shall be provided between incoming and outgoing sewers on all manholes.
11. Elevation: In all buildings in which any building drain is too low to permit gravity flow to the public sewer, sanitary sewage carried by such building drain shall be

lifted by a grinder pump system as specified in Section A and discharged to the building sewer.

12. Clean Outs: Clean-outs shall be installed at the property line, at every fitting over 22½ degrees and at 75-foot intervals. Service connections which are longer than 150-feet shall have sanitary manholes installed at a location(s) as directed by the Superintendent.
13. Pipe Size: All lateral sewer pipes shall have a minimum diameter of eight (8) inches. Sewer pipes for house connections from the sewer main to the property line shall have a minimum diameter of six (6) inches.
14. Backflow Valve: One backflow valve per unit shall be installed prior to connection to the sewer system for all residential and multi-unit dwellings.
15. Grease, Oil and Solids Interceptors: Grease, oil and solids Interceptors shall be in accordance with Woonsocket's Industrial Pretreatment Program.
16. Identification:
 - a. Underground-Type Line Markers for Piping: Manufacturer's standard permanent detection tape, bright colored, continuous-printed polyethylene tape with a metallic core for easy detection of underground installations, intended for direct burial service; not less than 6-inches wide x 4 mils thick. Provide green detection tape with black printing reading "**CAUTION SEWER LINE BURIED BELOW**" as manufactured by Seton or equal.
 - b. Installation marker 2-feet above top of pipe.

END OF SECTION

**SECTION II
SPECIFICATIONS**

1. **PART 1 – GENERAL**

1.1 **DESCRIPTION OF WORK:**

- A. The work consists of furnishing and installing a sanitary sewerage system(s) including precast concrete manholes with accessories, pipe, pipe fittings and accessories, connections to other piping and structures, testing of manholes and piping, jointing, and jointing materials, by-pass sewage handling, excavation and backfill, bedding material, sand blanket, and all other related and appurtenant work, complete in place in accordance with the requirements set forth, and/or as directed.

1.2 **SPECIAL REQUIREMENTS:**

- A. All approvals and permits as set forth in the North Smithfield Sewer Ordinance must be obtained prior to constructions of sanitary sewage system.
- B. The North Smithfield Sewer Department (NSSD) shall be notified forty-eight (48) hours in advance to inspect construction, witness testing of pipelines and manholes and making connections to existing sanitary manholes.

1.3 **QUALITY ASSURANCE:**

- A. **Manufacturer's Qualifications:** Firms regularly engaged in manufacture of sanitary sewerage system's products of types, materials, and sizes required, whose products have been in satisfactory use in similar service for not less than five (5) years.

1.4 **SUBMITTALS:**

- A. **General:** All submittals shall be submitted to the Sewer Superintendent, Town of North Smithfield, Memorial Town Building, Slatersville, Rhode Island.
- B. **Contract Drawings:** Submit three sets of drawings of proposed sanitary sewage system for review.
- C. **Record Drawings:** At completion of project, submit record drawings of installed sanitary sewerage piping showing a minimum of three ties from permanent installations such as poles, hydrants, etc., for manholes and service connections at main, property line, dwelling units and distances.

2. **PART 2 - PRODUCTS**

2.1 **PIPE:**

- A. Polyvinyl Chloride Pipe (6"-15") and Fittings: Polyvinyl chloride (PVC) sewer pipe and fittings shall be in accordance with the latest issue of ASTM D3034, SDR35 and applicable documents. The PVC sewer pipe and fittings shall be composed of clean, virgin, Class 12364C compounds conforming to ASTM D1784 and shall be bell and spigot with rubber ring joints. The bell shall consist of an integral wall section with a solid cross section rubber ring securely locked in place to prevent dislocation of the ring. Standard lengths shall be 20-feet and 12.5-feet, plus or minus 1-inch. Minimum "pipe stiffness": at 5% deflection shall be 46 for all sizes when tested in accordance with ASTM Designation D2412, external loading properties of plastic pipe by parallel-plate loading. All fittings and accessories shall be manufactured and furnished by the pipe supplier and have bell and/or spigot configurations compatible with that of the pipe fittings and shall be of the same strength and quality as the pipe.
- B. Polyvinyl Chloride Pipe (greater than 15") and Fittings: Polyvinyl chloride (PVC) sewer pipe and fittings shall be in accordance with the latest issue of ASTM F679. The PVC sewer and fittings shall be composed of clean, virgin, Class 12454C or 13364C compounds and shall be bell and spigot with rubber ring joints. The bell shall consist of integral wall section with a solid cross section rubber ring. Standard lengths shall be 13-feet plus or minus 1-inch. Minimum "pipe stiffness": at 7½% deflection shall be 46 for all sizes when tested in accordance with ASTM Designation D2412. All fittings and accessories shall be as manufactured and furnished by the pipe supplier and have bell and/or spigot configurations compatible with that of the pipe fittings and shall be of the same strength and quality as the pipe.
- C. Polyvinyl Chloride Pressure Pipe (6"-12") and Fittings: Polyvinyl Chloride (PVC) pressure pipe and fittings shall be in accordance with AWWA C900 and shall be bell and spigot with rubber ring joints. The pipe shall be manufactured from PVC cell Class 12454-13 in accordance with ASTM D1784. The pipe and fittings shall be Class 150 (DR18) with bell and spigot.
1. Restrained Joint Pipe Fittings:
- a. In lieu of thrust blocks, mechanical joint restraints may be used. Calculations shall be submitted to the Sewer Superintendent as to the pipe lengths that will require the restraints.
 - b. Retainers for PVC pipe bells shall be cast from 60-42-10 ductile iron, as manufactured by EBAA Iron, or equal. These devices shall have a sufficient number of ductile tie bolts to restrain working and test pressures as stated by the manufacturer. Each ductile clamp shall have serrations on the I.D. sufficient to hold working and test pressures. These devices shall be used to restrain pipe joints adjacent to the restrained fittings. The 1500 and 6500 are used in place of concrete thrust blocks, steel clamps and tie rods.
 - c. When it is required to restrain PVC push-on joints adjacent to restrained fittings, a harness restraint device shall be used. This harness restraint

shall be split to enable installation of the restraint after the spigot has been installed into the bell. The restraint shall consist of three major parts: the first part being a split ring that fits behind the bell; the second part being a split restraint ring that installs on the spigot; the third part being a number of tie bars to connect parts one and two to facilitate joint restraint. All of these components shall be cast of ductile iron conforming to ASTM A536-80. The restraint ring shall consist of a plurality of individually activated gripping surfaces to hold the spigot and maximize restrain capability. The harness restraint shall have a working pressure of at least 100 psi with a minimum safety factor of 2:1 and shall be EBAA Iron, Inc., MEGALUG® series 1100HV, or equal.

- D. Ductile Iron Pipe and Fittings: Ductile iron pipe shall be furnished in accordance with ANSI Designation A21.51. The ductile iron pipe shall be thickness Class 52. Pipes shall have normal laying lengths of at least 18-feet. In addition, each length of pipe shall be cement lined and receive a factory applied interior and exterior coating of Kopper's Bitumastic Super Service Black or an approved coating of equal specifications in accordance with ANSI Designation A21.4. Ductile iron pipe shall be push-on type of joint which employs rubber gasket. Joints shall be in accordance with the latest ANSI standard for "Rubber Gasket joints for Ductile Iron Pressure Pipe and Fittings", Designation A21.11. Fittings shall be in accordance with ANSI 23.53 with mechanical joints. The fittings shall be coated inside and outside with a bituminous asphalt paint.

1. Restrained Joint Pipe and Fitting:

- a. In lieu of thrust blocks, mechanical joint restraints may be used. Calculations shall be submitted to the Sewer Superintendent as to the pipe lengths that will require the restraints. Mechanical joint restraints shall be incorporated in the design of the follower gland and shall include a restraining mechanism which, when actuated, imparts multiple wedging action against the pipe, increasing its resistance as the pressure increases.
- b. Flexibility of the joint shall be maintained after burial. Glands shall be manufactured of ductile iron conforming to ASTM A536. Restraining devices shall be of ductile iron heat treated to a minimum hardness of 370 BHN. Dimensions of the gland shall be such that it can be used with the standardized mechanical joint bell and tee-head bolts conforming to ANSI/AWWA A21.11 and ANSI/AWWA C153/A21.53 of latest revision. Twist-off nuts shall be used to ensure proper actuating of the restraining devices. The mechanical joint restraint device shall have a working pressure of at least 250 psi with a minimum safety factor of 2:1 and shall be EBAA Iron, Inc. MEGALUG® or equal.

- E. Flexible Couplings: Flexible couplings where used shall be as manufactured by Fernco Co. or equal. Flexible couplings shall conform to ASTM C443, C425, C564 and D1869.

The couplings shall be stainless steel clamps. Donuts are not allowed to be used in lieu of flexible couplings.

- F. Mechanical Couplings: Mechanical couplings shall be ductile iron Style 38 as manufactured by Dresser, or equal, coated with a corrosion resistant coating applied by the factory.
- G. Insulation of Underground Piping:
 - 1. Insulation: Foam glass insulation, ASTM C552, "Specifications for Cellular Glass Thermal Insulation" shall be a minimum of 3-inches in thickness as manufactured by Pittsburgh Corning Corporation or equal.
 - 2. Jacketing: The jacketing shall be Pittwrap Jacketing as manufactured by Pittsburgh Corning Corporation or equal.
 - 3. Asphalt Coating: Pittcote 300 finish by Pittsburgh Corning Corp. or equal.
 - 4. Reinforcing Fabric: PC Fabric 79 by Pittsburgh Corning Corp. or equal.
 - 5. Strapping Tape: Glass fiber reinforced, 1-inch wide, Scotch Brand No. 880 by 3M or equal.
 - 6. Bore Coating: Hydrocal B-11 by U.S. Gypsum or equal.
- H. Thrust Blocks: Concrete for thrust blocks shall be 3000 psi concrete.

2.2 CHIMNEYS:

- A. Precast Units: The concrete shall be 5000 psi conforming to ASTM C150. Air entraining shall conform to ASTM C233, and the reinforcing shall conform to ASTM A615. All brackets, bolts, and nuts shall be stainless steel, and between each precast section there shall be a neoprene gasket.

2.3 MANHOLES:

- A. Poured-in-Place Manholes: Concrete for the bases or a complete manhole shall be 5000 psi. The bases or complete manholes shall be designed to withstand H2O loading without failure. Reinforcing steel shall be new deformed steel base conforming to ASTM 615. Grade of steel shall be ASTM Grade 40 minimum. The exterior of the manhole shall be damp proofed with an asphaltic compound as manufactured by Hydrocide.
- B. Precast Concrete Manholes: Manhole barrels, cone sections, bases, and entrance slabs shall consist of precast reinforced concrete manufactured in accordance with ASTM Standard Specifications for "Reinforced Concrete Manhole Risers and Tops", Designation C478 latest revision. The horizontal joints between sections shall be sealed using a flexible butyl resin sealant and shall conform to Federal Specifications SS-S-210A and

AASHTO M-198B. The exterior of the manhole shall be dampproofed with an asphaltic compound as manufactured by Hydrocide.

- C. Drop Manholes: Drop piping shall be the same size as sewer inlet. The concrete encasement for the outside drop piping shall be 3000 psi. Forms shall be used for the concrete encasement. The manhole shall be as specified for either cast-in-place or precast concrete manholes.
- D. Pipe Connectors: Resilient complying with ASTM C923. For pipes up to 24-inches, the pipe connectors shall be Kor-N-Seal and for pipe over 24-inches, the pipe connector shall be A-Lok or equal.
- E. Manhole Steps: Manhole steps shall be of safety type and shall be cast into the units during process of manufacture. Steps shall be steel reinforced copolymer polypropylene plastic step conforming to ASTM C478 or aluminum forgings alloy 6016, Temper T-16 and those parts which are embedded in the concrete shall be thoroughly cleaned and given a heavy coating of zinc chromate or other approved paint. In addition, steps shall conform to OSHA regulations.
- F. Frame and Covers: Manhole frames and covers shall be of tough gray cast iron, true to pattern and free from flaws. The bearing surfaces of the covers and frames shall be machined so as to give continuous contact throughout their circumference. The design on the cover top shall be the diamond with "SEWER" lettering cast into the top surface.
- G. Brick Masonry and Mortar Cement: Brick shall be Grade SM, ASTM C32 or Grade SM, AASHTO M91. All brick shall be common hard-rubber clay brick and shall be uniform and regular in shape and size. Mortar cement for masonry shall conform to ASTM Designation C-144. The mortar shall be composed of one (1) part masonry cement to 2½ parts sand with water not to exceed 4.1 gallons per 70-pound bag of masonry cement. If using Portland cement, lime putty may be added in such amounts that the hydrated lime does not exceed 15% by weight of cement.

2.4 GRAVEL BASE

- A. Gravel shall be free of foreign material such as loam, silt, clay and vegetable matter and meet the following requirements:

1.	Passing 1¼-inch sieve	100%
2.	Passing ¾-inch sieve	30-65%
3.	Passing No. 40	5-50%
4.	Passing No. 100	0-10%

2.5 BEDDING MATERIAL:

- A. The bedding material shall be crushed stone consisting of durable crushed rock or durable crushed gravel stone, free from ice, snow, sand, clay, loam or other deleterious material. The crushed stone shall conform to the following requirements:

1.	Passing ¾-inch sieve	100%
2.	Passing ½-inch sieve	10-50%
3.	Passing ⅜-inch sieve	0-20%
4.	Passing No. 4 sieve	0-5%

2.6 SAND BLANKET:

A. The sand shall be free from ice, snow, roots, sod, rubbish, and other deleterious or organic matter. The sand blanket shall conform to the following requirements

1.	Passing ½-inch sieve	100%
2.	Passing ⅜-inch sieve	85-100%
3.	Passing No. 4 sieve	60-85%
4.	Passing No. 16 sieve	35-60%
5.	Passing No. 50 sieve	10-35%
6.	Passing No. 100 sieve	2-10%

2.7 BACKFILL:

A. Backfill shall be excavated material free-draining clean granular soil suitable for backfill. Up to 20% of backfill material may be rock-like materials not to exceed 0.05 cubic feet in volume, nor more than 6-inches in length. The backfill shall not contain any debris, pavement, frozen material, organic matter or peat.

3. PART 3 - EXECUTION

3.1 PROJECT CONDITIONS:

A. Protection of Water Line:

1. Horizontal Separation: Sewers shall be laid at a minimum at least 10-feet, horizontally, from any existing or proposed water main or service. Should local conditions prevent a lateral separation of 10-feet, the sewer line shall be constructed of AWWA C900 polyvinyl chloride or Class 52 ductile iron pressure pipe.
2. Vertical Separation: Whenever sewers cross under water mains, or services, the sewer shall be laid at such an elevation that the top of the sewer is at least 18-inches below the bottom of the water main. When the elevation of the sewer cannot be relocated to provide this separation, the sewer line shall be constructed of AWWA C900 polyvinyl chloride or Class 52 ductile iron pressure pipe for a distance of 10-feet on each side of the water main.

B. Private Wells: Sewers shall be laid at a minimum at least 50-feet, horizontally, from any existing or proposed private well. Should local conditions prevent a lateral separation of 50-feet, the sewer line shall be constructed of AWWA C900

polyvinyl chloride or Class 52 ductile iron pressure pipe from manhole to manhole reach including the service connection pipe.

3.2 INSPECTION:

- A. The Superintendent of the NSSD shall be notified prior to installation of a sanitary sewer system so that inspections can be made throughout the project.
- B. The testing of sewer lines and manholes shall be conducted in the presence of the Representatives of NSSD. The NSSD shall be notified forty-eight (48) hours in advance of any testing.
- C. Connections made to existing manholes for lateral sewers shall be inspected by the NSSD prior to backfill.
- D. Connections to manholes for service connections are not allowed.
- E. If during inspections it is found that the sewage system is not in compliance with the specifications or details, the deficiencies shall be corrected immediately to the satisfaction of the NSSD. The NSSD will not allow any further construction of the sewage system until such time the deficiencies are corrected.

3.3 PRODUCT HANDLING:

- A. Each product shall be handled into its position in the trench in such a manner and by such means as the manufacturer recommends as satisfactory, and these operations will be restricted to those considered safe for the workmen and such as to cause no injury to the product or any property.
- B. The Contractor will be required to furnish slings, straps, and/or other devices to provide satisfactory support of the pipe when it is lifted. Transportation from delivery areas to the trench shall be restricted to operations which can cause no injury to the product. The products shall not be dropped from trucks or into the trench.
- C. The Contractor shall have on the job site with each crew, all the proper tools to handle the products being installed. The use of hammer and chisel or any other method which results in rough edges, chips and damages, shall be prohibited.

3.4 EXCAVATION AND BACKFILL FOR PIPES:

- A. The width of the trench shall be held to a minimum consistent with the space required to permit satisfactory jointing of the pipe and tamping of the bedding and backfill material under and around the pipe. In general, the maximum trench width shall be the pipe diameter plus 2-feet or a minimum width of 3-feet, whichever is greater. If necessary, sheeting and/or shoring shall be used to prevent overcutting at the level of the top of the pipe and to maintain the trench sides. The trench bottom should be smooth, level and all large stones or rocks lying on or protruding from the trench bottom shall be removed.

- B. Over-excavation shall be refilled in 6-inch lifts with approved granular material and compacted to 95% maximum density.
- C. Where unsuitable material is encountered at the trench bottom, the material shall be excavated to a stable bottom and refilled with compacted bedding material in 6-inch lifts.
- D. Backfill from the centerline of the pipe to the height 2-feet above the pipe shall be sand blanket material placed evenly the full width of the trench and compacted. The remainder of the trench shall be backfill material and compacted in 12-inch layers. Cushion and backfill material shall be compacted to 95% maximum density by tamping and compacting in layers (1-foot maximum) to achieve the required compaction.

3.5 INSTALLATION OF PIPE:

- A. Each pipe length shall be inspected for cracks, defects in coating or lining, and any other evidences of unsuitability. Before lowering in place, the pipe shall be struck with a suitable tool to verify its soundness.
- B. Pipe shall be laid in the dry and at no time shall water in the trench be permitted to flow into the sewer.
- C. The pipe shall then be laid on the trench bedding as shown in the trench detail, and the spigot pushed home. Jointing shall be in accordance with the manufacturer's instructions and appropriate ASTM standards, and the Contractor shall have on hand for each pipe-laying crew, the necessary tools, gauges, pipe cutters, etc. necessary to install the pipe in a workmanlike manner. Pipe laying shall proceed upgrade with spigot ends pointing in the direction of flow.
- D. Blocking under the pipe will not be permitted except where a concrete cradle is proposed, in which case precast concrete blocks shall be used.
- E. After the pipe has been set to grade, additional bedding material shall be placed in 6-inch layers up to the spring line of the pipe. Tamping bars shall be carefully employed to assure compaction of the bedding under the lower quadrants of the pipe for the full width of trench excavation.
- F. If a trench box is being used and the trench box is below the spring line of the pipe, the trench box shall be lifted vertically and the stone bedding shall be thoroughly compacted to the trench wall. The trench box shall not be pulled horizontally along the trench.
- G. At any time that work is not in progress, the end of the pipe shall be suitability closed to prevent the entry of animals, earth, water, etc.
- H. Unsatisfactory work shall be dug up and re-installed to the satisfaction of the NSSD.
- I. House service installations shall be as shown on the "Standard House Connection Detail". House services shall not be connected directly to manholes unless otherwise approved by

the NSSD. The opening of the house service, wye branch or chimney shall be suitably plugged with a watertight cap or plug. Before backfilling, the Contractor shall make the necessary measurements to locate the opening with a minimum of three ties later and the information shall be given to the NSSD. In addition, an approved ferrous rod or pipe shall be placed over the plugged opening, extending to within 2-inches of the final ground surface and metallic detection tape shall be installed a minimum of 24-inches above the pipe.

3.6 INSTALLATION OF MANHOLES:

- A. Bases for all sanitary sewer manholes shall be placed on a minimum of 6-inches of compacted bedding material. The excavation shall be properly dewatered and maintained dry while placing bedding material and setting the bases. Manholes shall be backfilled evenly and in layers, maximum 1-foot thick, with suitable backfill material and compacted to achieve 95% maximum density.
- B. Sheeting and/or bracing shall be used when required.
- C. Manhole barrel and cone sections shall be set so as to be vertical and in true alignment.
- D. Where required for future connections, openings shall be cast in the manholes at the proper location and shall be sealed with plugs.
- E. Drop manholes shall be built in accordance with the details.
- F. The inverts of all manholes shall be constructed of brick and formed in accordance with the details.
- G. Bricks shall be laid in a workmanlike manner, true to line and the joints shall be carefully struck and pointed on the inside. Bricks shall be thoroughly wet when laid and each brick shall be laid in mortar so as to form full bed, end and side joints in one operation. The outside of the brickwork shall be neatly plastered with ½-inch layer of cement mortar as the work progresses. The brickwork shall be satisfactorily bonded to the concrete and cast iron frame. No brick masonry shall be laid in water, or any water allowed to rise on the brickwork until the masonry has set for at least 24-hours.
- H. All lift holes shall be filled with non-shrinking mortar such as Quick-Plug prior to backfilling.

3.7 CONNECTIONS TO EXITING MANHOLES:

- A. Connections to existing manholes of lateral sewers shall be made so as not to damage the structure and shall be watertight with zero leakage. The crown of the new pipe shall be at the same elevation as the main of the largest existing pipe. The openings shall be cored and Kor-N-Tee boot shall be installed. The inverts shall be modified as directed to accommodate flow from the new pipe.

3.8 PLACEMENT OF THRUST BLOCKS:

- A. Thrust blocks shall be of sufficient size to withhold the test pressure, and they shall be paired against undisturbed earth. The concrete shall be kept clear of pipe joints.

3.9 RESTRAINED JOINTS:

- A. The mechanical joint restraints shall be installed in accordance with the manufacturer's written instructions.

3.10 BY-PASS SEWAGE HANDLING:

- A. As the construction of the sewer progresses and it becomes necessary to interrupt live sewage flow in any existing sanitary sewer, house lateral, manhole or portion thereof, the Contractor shall be required to divert such flows around the area of interruption.
- B. The existing sewage flow rate shall be continually maintained at all times and no loss of sewer service up or downstream of the interruption shall occur. The Contractor shall utilize quality materials and equipment in good repair in meeting the requirements of this special provision and all damages resulting from interruptions in the functioning of the by-pass sewage handling system shall be borne totally by the Contractor. The Contractor shall complete the adjacent construction in a timely fashion to minimize the duration of by-pass sewage handling required. Existing sewage flows shall be diverted and maintained until the new sewer construction is leakage tested and accepted for service by the NSSD.

3.11 TESTING GRAVITY SEWERS:

- A. General: Testing of each section of sewer installed shall include the portions of service connections that are to be installed in the presence of the NSSD. The Contractor shall test each manhole reach as soon as construction of such reach is complete. The Contractor will be required to perform the pipe deflection test on each section of pipe installed, vacuum test of manholes and an infiltration test or low pressure test as applicable.

- B. Pipe Deflection: Test each section of PVC sewer pipe for vertical ring deflection sixty (60) days following installation. In the presence of the NSSD, maximum allowable ring deflection shall be 7½% of inside diameter.

1.	6-inch pipe, inside dia.:	5.742", 7½% deflection -	5.31"
2.	8-inch pipe, inside dia.:	7.665", 7½% deflection -	7.09"
3.	10-inch pipe, inside dia.:	9.563", 7½% deflection -	8.84"
4.	12-inch pipe, inside dia.:	11.361", 7½% deflection -	10.51"
5.	15-inch pipe, inside dia.:	13.858", 7½% deflection -	12.86"

- C. Infiltration Test: An infiltration test requires groundwater levels to be a minimum of 2-feet above the crown of the pipe of the high end of the section being tested. The Contractor shall have on hand all plugs, pumps, weirs, water trucks, etc., necessary to conduct the tests.

1. Each manhole to manhole reach of pipeline shall be tested.
2. With all connecting pipes plugged (other than those included in test section), a V-notch weir shall be installed in the downstream end of pipe. The V-notch weir must be constructed accurately and installed to maintain a watertight seal between weir and pipe.
3. Time shall be allowed for water to build up behind weir until steady, uniform flow passes through V-notch.
4. Readings shall then be taken under direction of the NSSD and recorded.
5. Should the work fail the infiltration test, corrective action shall be taken by the Contractor, in a manner approved by the NSSD. The sewer pipe shall be internally inspected with a camera to identify and locate the infiltration source(s). The Contractor shall excavate and make the necessary repair to the satisfaction of the NSSD. The repair(s) shall be air tested with zero pressure drop after two minutes.
6. Leakage shall not exceed 10 gallons per inch diameter, per day, per mile of pipe. Should the pipe, as laid, fail to meet the requirements, the Contractor shall perform the necessary work to meet these requirements.

D. Low Pressure Air Test:

1. After completing backfill of the pipeline, the Contractor shall conduct a line acceptance test using low pressure air. The test shall be performed according to stated procedures and in the presence of the NSSD personnel. The line shall be flushed and cleaned prior to testing.
2. All pneumatic plugs shall be seal tested before used in the actual test installation. One (1) length of pipe shall be laid on ground and sealed at both ends with the pneumatic plugs to be checked.

Air shall be introduced into the plugs to 25 psig. The plugs shall hold against this pressure without bracing and without movement of the plugs out of the pipe.
3. After a manhole to manhole reach of pipe has been backfilled and cleaned, and the pneumatic plugs are checked by the above procedure, the plugs shall be placed in the line at each manhole and inflated to 25 psig. Low pressure air shall be introduced into this sealed line until the internal air pressure reaches 4 psig greater than the average back pressure of any groundwater that may be over the pipe. At least two minutes shall be allowed for the air pressure to stabilize.
4. After the stabilization period (3.5 psig minimum pressure in the pipe), the air hose from the control panel to the air supply shall be disconnected. The time required in minutes for the pressure to decrease from 3.5 to 2.5 psig (greater than the

average back pressure of any groundwater that may be over the pipe) shall not be less than the time shown for the given diameters in the following:

- a. 8 inches -- 4 minutes
- b. 10 inches -- 5 minutes
- c. 12 inches -- 6 minutes
- d. 18 inches -- 9 minutes
- e. 21 inches -- 10 minutes
- f. 24 inches -- 12 minutes
- g. 27-inches -- 13 minutes
- h. 30 inches -- 15 minutes
- i. 36 inches -- 17 minutes
- j. 42 inches -- 20 minutes
- k. 48 inches -- 23 minutes

5. If the installation fails the air test, the Contractor shall, at his expense, determine the source of leakage. The sewer pipe shall be internally inspected with a camera and each pipe joint shall be tested. The identified defect shall be repaired. The Contractor will not be allowed to use sealants but will be required to excavate and make the necessary repair to the satisfaction of the NSSD and the pipeline shall be retested.

3.12 TESTING OF PRESSURE LINES:

- A. Upon completion of installation of the force main, the line shall be tested for leaks. The Contractor shall make all necessary arrangements for obtaining potable water, furnishing all pumps, piping, hose, installing corporation stops if necessary, etc.
- B. Air shall be expelled by filling the main slowly and permitting air to escape at high points. Air bleeder shall be installed in location directed by the NSSD.
- C. Pressure pipelines shall be subjected to a pressure test of 150 psi. The test pressure shall be maintained for a minimum of two (2) hours. The leakage rate allowed is 0.
- D. Any defective joints shall be immediately repaired, and any cracked or otherwise defective pipe shall be replaced by the Contractor and the test repeated.

3.13 TESTING OF MANHOLES:

- A. General: Tests shall be made and observed by the NSSD on each manhole.
- B. Vacuum Test Before Backfilling: Install vacuum tester and inflate compression band to effect a seal between the vacuum base and the manhole, connect vacuum pump to the outlet part with the valve open, draw a vacuum of 10 inches of mercury (HG), and close the valve. The manhole shall pass the test if the vacuum remains at 10-inches of HG or drops to 9-inches of HG in a time greater than 60 seconds for a 48-inch diameter manhole, time greater than 75 seconds for 60-inch diameter manhole and time greater than 90

seconds for 72-inch diameter manhole. If the manhole fails the initial test, the Contractor shall make proper repairs or replace the manhole and retest at no additional compensation.

END OF SECTION

SANITARY SEWAGE SERVICE CONNECTIONS

1. PART 1 - GENERAL

1.1 DESCRIPTION OF WORK:

- A. The work consists of furnishing and installing service connections from the property line to building or from the main line to the building including, but not limited to, installation of appropriate fittings at the main sewer line, fittings at property line, construction of chimneys if required, construction of clean-outs, excavation, bedding, sand cushion, backfilling, recording location, and all other related and appurtenant work, complete in place in accordance with details and specifications, and as directed by North Smithfield Sewer Department (NSSD).

1.2 SPECIAL REQUIREMENTS:

- A. Contractor shall obtain all required permits as set forth in the North Smithfield Sewer Ordinance prior to undertaking construction of sanitary sewage service connection(s).
- B. The Sewer Superintendent shall be notified forty-eight (48) hours in advance to inspect the installation of the sanitary sewage service connection(s).
- C. Connections to sanitary manholes are not allowed.

2. PART 2 - PRODUCTS

2.1 PIPE:

- A. Polyvinyl Chloride and Fittings: Polyvinyl chloride (PVC) sewer pipe and fittings shall be in accordance with the latest issue of ASTM Specification D3034, SDR-35 and applicable documents. The PVC sewer pipe and fittings shall be composed of clean, virgin, Class 12454-B compounds conforming to ASTM D1784 and shall be bell and spigot with rubber ring joints. The bell shall consist of an integral wall section with a solid cross section rubber ring securely locked in place to prevent dislocation of the ring. Standard lengths shall be 20-feet and 12.5-feet, plus or minus 1-inch. Minimum "pipe stiffness" at 5% deflection shall be 46 for all sizes when tested in accordance with ASTM Designation D2412, external loading properties of plastic pipe by parallel-plate loading. All fittings and accessories shall be manufactured and furnished by the pipe supplier and have bell and/or spigot configurations compatible with that of the pipe fittings and shall be of the same strength and quality as the pipe.
- B. Polyvinyl Chloride Pressure Pipe and Fittings: Polyvinyl chloride (PVC) pressure pipe and fittings shall be in accordance with AWWA C900, etc. bell and spigot with rubber ring joints. The pipe and fittings shall be Class 150 (DR18) with bell and spigot.

2.2 CHIMNEYS:

- A. Precast concrete units (5000 psi concrete) with stainless steel brackets, bolts, and nuts, and neoprene gaskets between sections will be allowed.

2.3 FLEXIBLE COUPLINGS:

- A. Flexible couplings shall be as manufactured by Fernco or equal. The flexible coupling shall conform to ASTM C443, C425, C564, and D1869. The coupling shall have stainless steel clamps. Donuts are not allowed to be used in lieu of flexible couplings.

2.4 SEWER PIPE SADDLE:

- A. Sewer pipe saddles shall be Sealtite Type "D" Tee Sewer Pipe Saddle or Type "E" Wye Sewer Pipe Saddles as manufactured by Geneco Products or equal.
- B. Saddle shall be cast iron conforming to ASTM A-48, Class 35 and shall be coated with a black asphaltum type paint.
- C. Saddle gaskets shall be one piece, rubber O-rings, maintaining a leak-proof connection, conforming to ASTM DT869.
- D. Saddle shall be secured to the existing sewer main with type C304 stainless steel band with stainless steel bolts.

2.5 GRAVEL BASE

- A. Gravel shall be free of foreign material such as loam, silt, clay and vegetable matter and meet the following requirements:
 - 1. Passing 1¼-inch sieve 100%
 - 2. Passing ¾-inch sieve 30-65%
 - 3. Passing No. 40 5-50%
 - 4. Passing No. 100 0-10%

2.6 BEDDING MATERIAL:

- A. The bedding material shall be crushed stone consisting of durable crushed rock in durable crushed gravel stone, free from ice, snow, sand, clay, loam, or other deleterious material. The crushed stone shall conform to the following requirements
 - 1. Passing 1-inch sieve 100%
 - 2. Passing ¾-inch sieve 90-100%
 - 3. Passing ½-inch sieve 10-50%
 - 4. Passing ⅜-inch sieve 0-20%
 - 5. Passing No. 4 sieve 0-5%

2.7 SAND BLANKET:

A. The sand shall be free from ice, snow, roots, rubbish, and other deleterious or organic matter. The sand blanket shall conform to the following requirements:

1.	Passing ½-inch sieve	100%
2.	Passing ⅜-inch sieve	85-100%
3.	Passing No. 4 sieve	60-85%
4.	Passing No. 16 sieve	35-60%
5.	Passing No. 50 sieve	10-35%
6.	Passing No. 100 sieve	2-10%

2.8 BACKFILL:

A. Backfill shall be excavated materials free-draining clean granular soil suitable for backfill. Up to 20% of backfill material may be rock-like materials not to exceed 0.05 cubic feet in volume, nor more than 6-inches in length. The backfill shall not contain any debris, pavement, frozen material, organic matter, or peat.

3. PART 3 - EXECUTION

3.1 PROJECT CONDITIONS:

A. Protection of Water Line:

1. Horizontal Separation: Sewers shall be laid at a minimum at least 10-feet, horizontally, from any existing or proposed water main or service. Should local conditions prevent a lateral separation of 10-feet, the sewer line shall be constructed of AWWA C900 polyvinyl chloride or Class 52 ductile iron pressure pipe.
2. Vertical Separation: Whenever sewers cross under water mains, or services, the sewer shall be laid at such an elevation that the top of the sewer is at least 18-inches below the bottom of the water main. When the elevation of the sewer cannot be relocated to provide this separation or the sewer line shall be constructed of AWWA C900 polyvinyl chloride or Class 52 ductile iron pressure pipe for a distance of 10-feet on each side of the water main.

B. Private Wells:

1. Sewers shall be laid at a minimum at least 50-feet, horizontally, from any existing or proposed private well. Should local conditions prevent a lateral separation of 50-feet, the sewer line shall be constructed of AWWA C900 polyvinyl chloride or Class 52 ductile iron pressure pipe from manhole to manhole reach including the service connection pipe.

3.2 INSPECTION:

- A. The Contractor shall notify the NSSD forty-eight (48) hours in advance to make an inspection of the sanitary connection. The inspection(s) will be made prior to backfilling the trench. If more than one inspection is required to be made by the NSSD, the Contractor will be required to reimburse the NSSD for the associated costs involved in the re-inspection(s).
- B. If during the inspection(s) it is found that the installation of the service connection is not in compliance with these specifications or details, the Contractor shall immediately take corrective measures, and the service connection will be re-inspected at the Contractor's expense.

3.2 CONNECTIONS MADE AT EXISTING SEWER MAIN:

- A. The Contractor shall install a pipe saddle per manufacturer recommendations if a wye does not exist.

3.3 CONNECTIONS MADE AT PROPERTY LINE:

- A. The Contractor shall connect to the sewer service pipe located at the property line with a flexible coupling.
- B. The Contractor shall install a clean-out just upstream from the flexible coupling.

3.4 CLEAN-OUTS:

- A. Clean-outs shall be installed at the property line, at every fitting over 22½ degrees and at 75-foot intervals up to 150-feet. Service connections which are longer than 150-feet shall have sanitary manholes installed at a location(s) as directed by the NSSD.

3.5 EXCAVATION AND BACKFILL:

- A. The width of the trench shall be held to a minimum consistent with the space required to permit satisfactory jointing of the pipe and tamping of the bedding and backfill material under and around the pipe. In general, the maximum trench width shall be the pipe diameter plus 2-feet or a minimum width of 3-feet, whichever is greater. If necessary, sheeting and/or shoring shall be used to prevent overcutting at the level of the top of the pipe and to maintain the trench sides. The trench bottom should be smooth, level and all large stones or rocks lying on or protruding from the trench bottom shall be removed. Over-excavation will be refilled in 6-inch lifts with approved granular material and compacted to 95% maximum density.
- B. Where unsuitable material is encountered at the trench bottom, the material shall be excavated to a stable bottom and refilled and compacted bedding material in 6-inch lifts.

- C. Backfill from the centerline of the pipe to a height of 2-feet above the pipe shall be sand blanket material placed evenly the full width of the trench and compacted in 12-inch layers. The remainder of the trench shall be backfilled evenly with suitable (excavated or borrow) backfill material and compacted in 12-inch layers. Cushion and backfill material shall be compacted to 95% maximum density by tamping and compacting in layers (1-foot maximum) to achieve the required compaction.

3.6 INSTALLATION OF PIPE:

- A. Each pipe length shall be inspected for cracks, defects in coating or lining, and any other evidences of unsuitability. Before lowering in place, the pipe shall be struck with a suitable tool to verify its soundness.
- B. Pipe shall be laid in the dry and at no time shall water in the trench be permitted to flow into the sewer.
- C. The pipe shall then be laid on the trench bedding as shown on the standard trench detail, and the spigot pushed home. Jointing shall be in accordance with the manufacturer's instructions and appropriate ASTM standards, and the Contractor shall have on hand for each pipe-laying crew, the necessary tools, gauges, pipe cutters, etc., necessary to install the pipe in a workmanlike manner. Pipe laying shall proceed upgrade with spigot ends pointing in the direction of flow.
- D. Blocking under the pipe will not be permitted except where a concrete cradle is proposed, in which case precast concrete blocks shall be used.
- E. After the pipe has been set to grade, additional bedding material shall be placed in 6-inch layers up to the spring line of the pipe. Tamping bars shall be carefully employed to assure compaction of the bedding under the lower quadrants of the pipe for the full width of trench excavation.
- F. If inspection of the pipe is satisfactory, the Contractor may then backfill the remainder of the trench in accordance to the specifications and details.
- G. If a trench box is being used and the trench box is below the spring line of the pipe, the trench box shall be lifted vertically, and the stone bedding shall be thoroughly compacted to the trench wall. The trench box shall not be pulled horizontally along the trench.
- H. At any time that work is not in progress, the end of the pipe shall be suitably closed to prevent the entry of animals, earth, etc.
- I. Unsatisfactory work shall be dug up and re-installed to the satisfactory of the NSSD.

3.7 RECORDING LOCATION:

- A. The Contractor shall submit to the NSSD, after completion of the service connection(s), installation of a sketch showing the location of the service connection utilizing distances

from permanent structures. The depth at the sewer main property line and at the dwelling unit shall be recorded.

END OF SECTION

LOW PRESSURE SEWER GRINDER PUMP STATIONS

1. PART 1 - GENERAL

1.1 DESCRIPTION OF WORK:

- A. The work consists of furnishing and installing a grinder pump system including excavation and backfill, bedding material, grinder pump, pump chamber with accessway, piping and valves, electrical work, factory and on-site testing, and all other incidentals as specified and as shown on the contract drawings.
- B. All approvals and permits as set forth in the North Smithfield Sewer Ordinance and the Department of Environmental Management requirements, when applicable, shall be obtained prior to the installation of the low pressure grinder pump station system.

1.2 SPECIAL REQUIREMENTS:

- A. Contractor shall obtain all required permits as set forth in the North Smithfield Sewer Ordinance and the Department of Environmental Management prior to undertaking construction of sanitary sewage service connection(s).
- B. The Sewer Superintendent shall be notified forty-eight (48) hours in advance to inspect the installation.

1.3 SUBMITTALS:

- A. Contract Documents: Submit contract documents of proposed low pressure sewer grinder pump system including design calculations.
- B. Operation and Maintenance Service: Submit an operation and maintenance service contract for each grinder pump unit.
- C. Record Drawings: At completion of project, submit record drawings of installed system.

1.4 QUALIFICATIONS OF MATERIAL AND EQUIPMENT:

- A. Specific manufacturers' names and catalog numbers are used herein to establish quality and design of a particular item.
- B. Wherever in the Specifications any item of equipment or material is designated by reference to a particular brand, manufacturer, or trade name, it is understood that a reviewed equal product, acceptable to the North Smithfield Sewer Department (NSSD), may be submitted by the Contractor.
- C. If the Contractor proposes to use a material which, while suitable for the intended use, deviates in any way from the detailed requirements, he shall inform the NSSD in writing of

the nature of such deviations at the time the material is submitted for review, and shall request a review of the deviation from the requirements.

- D. In requesting a review of deviations or substitutions, the Contractor shall provide evidence leading to a reasonable certainty that the proposed substitution or deviation shall provide a result at least equal in quality to that specified. If, in the opinion of the NSSD, the evidence presented by the Contractor does not provide a sufficient basis for such reasonable certainty, the NSSD will reject such substitution or deviation without further investigation, in which case it shall be the responsibility of the Contractor to provide another product which is satisfactory to the NSSD.

2. PART 2 - PRODUCTS:

2.1 LOW PRESSURE GRINDER PUMP UNIT:

- A. Low pressure grinder pumps shall be manufactured by Environment One, or equal. The unit shall consist of a grinder pump, level controls, siphon breaker, check valve and 70 gallon high density polyethylene tank. The unit shall be equipped with an electrical quick disconnect plug, a discharge line shut-off valve and a quick disconnect assembly. The alarm/disconnect panel shall contain circuit breakers, an audible and visual alarm transfer switch and generator receptacle. A second check valve shall be provided at the curb stop.

2.2 PIPING:

- A. Low pressure pipe and fittings shall be polyvinylchloride pipe Class 200 (SDR 21) with push-on joints. Bell shall be gasketed joint conforming to ASTM D3139 with gaskets conforming to ASTM F477.
- B. Schedule 80 PVC pipe and fittings shall be rigid, unplasticized, Type I, Grade I, polyvinylchloride conforming to ASTM D1784, NSF listed.

2.3 ELECTRICAL EQUIPMENT:

- A. Manual transfer switch shall be a double throw non-fuse, 3-pole square "D" 30 amp enclosed in a NEMA 3R enclosure.
- B. The generator hook-up shall be a single outlet (2P - 3 wire) twist lock with a weatherproof cover plate NEMA L6-30 or with a 12-2 with ground power supply cord connected to the transfer switch with a male plug.
- C. All materials shall be U.L. listed, PVC conduits, conduit wall seals and conductors-copper and shall be acceptable to the local electrical inspector.

3. PART 3 - EXECUTION

3.1 INSTALLATION OF GRINDER PUMPING UNIT:

- A. Installation of grinder pumping unit shall be in accordance with the manufacturer's written instructions.
- B. Installation of piping and valves shall be in accordance to sanitary sewage system or sanitary sewage service connections specifications.

3.2 ELECTRICAL:

- A. Contractor shall obtain all required certificates of inspection of his work as required by state and local officials and deliver same to the NSSD.
- B. All materials furnished and all work installed shall comply with the national fire codes of the National Fire Protection Association, with the requirements of all Town, State and governmental departments having jurisdiction, including applicable requirements of the U.S. Department of Labor's occupational safety and health standards.
- C. Materials and workmanship shall be new and of current production and shall conform in all respects to, applicable requirements of national electrical code, rules, and regulations governing installation of electrical work in the applicable requirements of the utility company and other state and local authorities having jurisdiction.
- D. The high level indicator lamp assembly shall be installed in a standard device box in a visible location in the interior of dwelling.

3.3 START-UP SERVICE:

- A. A factory-trained representative shall perform initial start-up of each unit and instruct dwelling owner in the operation and maintenance of the equipment, and to test for satisfactory performances of each unit in the presence of the Sewer Superintendent.

3.4 OPERATION AND MAINTENANCE SERVICE:

- A. A two (2) year operation and maintenance service contract for the pumping unit shall be obtained by the Contractor or dwelling owner for each unit and submitted to the Sewer Superintendent prior to receiving a permit for installation.

END OF SECTION

1. PART 1 - GENERAL

1.1 DESCRIPTION OF WORK:

- A. Perform all work necessary and required for the construction of temporary pavement and replacement of temporary pavement. Such work includes but is not limited to the following:
 - 1. Gravel base course.
 - 2. Asphalt-aggregate, central-plant, hot-mix, bituminous pavement.
 - 3. Tack coat.
 - 4. Saw cutting and patching existing road.
- B. Bituminous paving shall conform to the requirements of the North Smithfield Department of Public Works.
- C. The Contractor is responsible for the roadway restoration on Town roadway for a one (1) year period from the day of acceptance by the Town of North Smithfield.

1.2 ENVIRONMENTAL CONDITIONS

- A. Bituminous paving shall not be placed when the ambient temperature is below 40F, when there is frost in the base, or any other time when weather conditions are unsuitable for the type of materials being placed.

1.3 PROTECTION

- A. After final rolling, no vehicular traffic of any kind shall be permitted on paving until it has cooled and hardened, and in no case less than six (6) hours.
- B. Any damaged pavement resulting from work under this contract shall be repaired by the Contractor.

2. PART 2 - PRODUCTS

2.1 MATERIALS:

A. Gravel Base Course

- 1. Gravel shall meet the following gradation requirements:

<u>SIEVE SIZE</u>	<u>PERCENT FINER BY WEIGHT</u>
a. 1/2"	50 - 85
b. 3/8"	45 - 80
c. No. 4	40 - 75
d. No. 40	0 - 45
e. No. 200	0 - 10

2.2 BITUMINOUS PAVEMENT MATERIALS

- A. Asphalt: The asphalt material shall conform to the requirements of the applicable table in "Specifications for Asphalt Cements and Liquid Asphalts", Specification Series No. 2, The Asphalt Institute. Paving asphalt shall be steam-refined paving asphalt with penetration grades of 85-100 for roads and 60-70 for parking areas. The amount of asphalt to be mixed with the mineral aggregate shall be between 3 - 6% by weight for binder course and between 6.5 - 8% by weight for wearing course. The exact amount of asphalt to be mixed with the mineral aggregate shall be such that a hard, unyielding paving will be the result.
- B. Mineral Aggregate: Coarse and fine mineral aggregate shall consist of broken stone, crushed gravel, natural materials having sufficient roughness when combined within the specified limits for grading, or a mixture thereof. If gravel is used, not less than 15% and nor more than 30% limestone screenings by weight shall be added to the gravel as a separate ingredient so as to meet the gradation limits. If crushed stone is used, not less than 15% nor more than 30% sand by weight shall be added to the crushed stone as a separate ingredient to meet the gradation limits. The material shall be tough, durable, and sound, and shall be free from organic matter and other deleterious substances, and shall conform to the following gradation:

1. <u>SIEVE SIZE</u>	<u>PERCENT PASSING BY WEIGHT</u>
<u>Wearing Course</u>	
a. 3/4-inch	100
b. 1/2-inch	80-100
c. 3/8-inch	70-90
d. No. 4	50-70
e. No. 8	35-50
f. No. 30	18-29
g. No. 50	13-23
h. No. 100	8-16
i. No. 200	3-8
<u>Binder Course</u>	
a. 1 1/4 inch	100
b. 3/4 inch	60-80
c. 3/8 inch	35-60

d.	No. 8	20-35
e.	No. 50	3-12
f.	No. 200	0-4

2. As a further requirement aggregate shall not vary from the specified gradation by more than the following tolerances:
 - a. Passing No. 4 and larger sieves - plus or minus 7.0%.
 - b. Passing No. 8 to No. 100 sieves - plus or minus 4.0%.
 - c. Passing No. 200 sieve - plus or minus 2.0%.

2.3 MIXING

- A. Surface course shall be mixed at a central mixing plant by either batch mixing or continuous mixing, at a temperature not exceeding 325F. The completed mixture, tested at any time or at any location, shall have a uniform distribution of asphalt binder, as determined by the extraction test, as performed in accordance with ASTM test method D2172.82. The bitumen ratio (pounds of asphalt per 100 pounds of dry aggregate), computed from laboratory extraction analysis, shall not vary more than 5% above or 10% below the exact amount predetermined to obtain hard unyielding paving.

2.4 TACK COAT

- A. Tack coat shall consist of either emulsified asphalt, Grade RS-1 or cutback asphalt Grade RC-70 or RC-250 conforming to the Rhode Island Department of Transportation Standard Specifications.

3. PART 3 - EXECUTION

3.1 REMOVE AND DISPOSE OF EXISTING PAVEMENT

- A. Existing bituminous pavement shall be removed and disposed of properly. All edges shall be saw cut to a straight smooth line.

3.2 PAVEMENT

- A. As soon as earth backfill has been compacted to 95% density, the 2-inch temporary pavement shall be placed. The temporary pavement shall remain for a period no less than 90 days at which time the Contractor shall remove the temporary pavement and re-sawcut the trench 12-inches beyond the temporary pavement edges and install the permanent pavement. The Contractor will be responsible for the temporary pavement during the 90-day period.

3.3 GRAVEL BASE COURSE

- A. Gravel base shall be of thickness indicated on detail.

3.4 SURFACE PREPARATION

- A. Immediately before applying binder course, the area to be surfaced shall be cleaned of all loose material. Binder course shall not be applied until base course preparation has been completed, and only so far in advance of placing the surfacing as may be permitted by the North Smithfield Department of Public Works.

3.5 BITUMINOUS PAVEMENT

- A. Surface Preparation: In advance of placing asphalt concrete and before placing adjacent to cold transverse construction joints, such joints shall be trimmed to a vertical face and to a neat line and tack coat shall be applied to all edges.
- B. Spreading: The surface shall be clean of all dirt, packed soil, or any other foreign material, and shall be dry when spreading the bituminous mixture. The mixture shall be spread in two courses and to the amount required to obtain the compacted thickness and cross section shown on the design drawings. The mixture shall be spread without disturbing the base course and struck off so that the surface is smooth and of uniform density throughout. Care shall be used in handling the mixture to avoid segregation. Areas of segregated mixture shall be removed and replaced with suitable mixture.
- C. Initial Rolling: The initial rolling shall consist of one complete coverage of asphalt mixtures and shall be performed with 3-wheel rollers or 2-wheel tandem rollers. Such rollers shall weigh not less than 12 tons. Rolling shall commence at the lower edge and shall progress toward the highest portion. Under no circumstances shall the center be rolled first. Rolling shall be performed with the drive wheel of the tandem roller forward with respect to the direction of spreading operations, unless otherwise permitted.
- D. Intermediate Rolling: The initial rolling shall be followed by additional rolling consisting of three completed coverages with an oscillating type pneumatic-tired roller developing at least 80 psi contact pressure while the temperature of the mixture is at, or above, 150F.
- E. Final Rolling: The final rolling of the uppermost layer of asphalt concrete shall be performed with either 2 or 3-wheel tandem rollers weighing not less than 10 tons. Rollers shall be operated at a speed of not more than 3 miles per hour and in a manner that will avoid cracking, pushing, or displacing the mixture during the compacting period. Rolling shall be continued until further compaction is obtained. All compacted mixtures shall have a density of not less than 95% of that obtained by a laboratory compaction of an identical mixture. The use of any equipment that leaves ridges, indentations, or other objectionable marks in the asphalt concrete shall be discontinued.
- F. Finish Surface: The complete surfacing shall be thoroughly compacted, smooth, and true to grade and cross section, and free from ruts, humps, depressions, or irregularities. When a straightedge 10-feet long is laid on the finished surface and parallel with the center line of the road, the surface shall not vary more than 3/16-inch from the lower edge of the straightedge. Any ridges, indentations, or other objectionable marks left in the surface of

the asphalt concrete by blading or other equipment shall be eliminated by rolling or other means.

- G. Special Instructions: In addition to the requirements of this specification, roadway paving shall conform to all state and local regulations and specifications.
- H. State Roads: On state roads, the Contractor shall obtain the required Utility Permit from RIDOT and the work shall be in accordance with the Permit.

END OF SECTION

1. PART 1 - GENERAL

1.1 DESCRIPTION OF WORK:

- A. Perform all work necessary and required for the replacement of existing concrete walks. Such work includes but is not limited to the following.
 - 1. Subgrade preparation
 - 2. Gravel base course
 - 3. Edging strips
 - 4. Furnishing and placing asphalt mix
- B. Bituminous concrete walks shall conform to the North Smithfield Department of Public Works requirements.

1.2 WEATHER LIMITATIONS:

- A. Asphalt mix shall be placed only when the specified density can be obtained. Precautions shall be taken at all times to compact the mix, shall not be placed on any wet surface or when weather conditions will otherwise prevent its proper handling or finishing. Asphalt mix shall not be placed when the air temperature is below 50F.

2. PART 2 - PRODUCTS

2.1 GRAVEL BASE COURSE

- A. Gravel shall meet the following gradation requirements:

1.	<u>SIEVE SIZE</u>	<u>PERCENT FINER BY WEIGHT</u>
a.	1/2"	50 - 85
b.	3/8"	45 - 80
c.	No. 4	40 - 75
d.	No. 40	0 - 45
e.	No. 200	0 - 10

2.2 ASPHALT MIX

- A. Mix shall be Type I-2, conforming to the requirements of the Standard Specification for Road and Bridge Construction, State of Rhode Island.

3. PART 3 - EXECUTION

3.1 TEMPORARY PAVEMENT

- A. As soon as earth backfill has been compacted to 95% density, the 2-inch temporary pavement shall be placed. The temporary pavement shall remain for 90 days at which time the temporary pavement will be removed and the pavement shall be saw cut 12-inches beyond the edges of the temporary pavement, tack coat the edges of the existing sidewalk and install permanent sidewalk pavement. The Contractor will be responsible for the temporary pavement during the 90-day period.

3.2 INSTALLATION

- A. Gravel Base Course: Gravel base shall be of 8-inches compacted thickness.

3.3 ASPHALT MIX

- A. The asphalt mix shall be placed in two lifts to provide a minimum compacted thickness of 1½-inches per lift. Placing the mixture shall be continuous operation. If any irregularities occur, they shall be corrected before final compaction of the mix.

3.4 FIELD QUALITY CONTROL

- A. Compacting: The mix shall be compacted immediately after placing. Initial rolling with a steel-wheeled or pneumatic-tired roller shall be done immediately behind the initial rolling. Final rolling shall eliminate marks from previous rolling. In areas too small for the roller, a vibrating plate compactor or a hand tamper shall be used to achieve thorough compaction.
- B. Density and Surface Requirements: The compacted asphalt mix shall have a density equal to or greater than 90% of a laboratory compacted specimen. The surface of the completed walk will be checked longitudinally for trueness with a 10-foot straight edge. The surface shall not vary more than 3/16-inch in 10-feet.

END OF SECTION

1. PART 1 - GENERAL

1.1 DESCRIPTION OF WORK:

- A. Perform all work necessary and required for the replacing of existing concrete walks. Such work includes but is not limited to the following:
1. Placement of temporary bituminous concrete pavement.
 2. Subgrade preparation.
 3. Gravel base course.
 4. Formwork.
 5. Concrete mixing, placing, finishing, and curing.
 6. Control and isolation joints.
 7. Precast lot curb.
 8. Cement concrete walks shall conform to the North Smithfield Department of Public Works requirements.
- B. The Contractor will be responsible for the restored concrete sidewalk for a period of one year from the date of acceptance by the Town. The Contractor shall repair damaged concrete and clean concrete discolored during this period. Sidewalk that is damaged shall be removed and reconstructed for the entire length between regularly scheduled joints. Refinishing the damaged portion will not be acceptable.

2. PART 2 - PRODUCTS

2.1 MATERIALS:

- A. Concrete: Concrete shall have a minimum compressive strength of 3000 lbs. per square inch at 28 days. The maximum size of coarse aggregate shall be 1½-inches. Concrete shall have a slump of not more than 3-inches. The concrete mixtures shall have air content by volume of concrete, based on measurements made immediately after discharge from the mixer, 5% to 7% air content shall be determined in accordance with ASTM C 173.
- B. Gravel Base Course: Gravel shall meet the following gradation requirements:

1.	<u>SIEVE SIZE</u>	<u>PERCENT FINER BY WEIGHT</u>
a.	½"	50 - 85
b.	¾"	45 - 80
c.	No. 4	40 - 75
d.	No. 40	0 - 45
e.	No. 200	0 - 10

3. PART 3 - EXECUTION

3.1 TEMPORARY PAVEMENT

- A. The Contractor shall place 2-inches temporary bituminous concrete pavement as soon as earth backfill has been compacted to 95% density. The temporary pavement shall remain for a period of 90 days prior to placement of concrete sidewalk. The Contractor will be responsible for the temporary pavement during the 90 day period and the Contractor shall remove the temporary pavement. All edges of the existing concrete sidewalk shall be saw cut before placement of new concrete sidewalk at the closest non-disturbed control or isolation joint.

3.2 SUBGRADE MATERIALS:

- A. The subgrade shall be constructed true to grade and cross section. The subgrade shall be thoroughly wetted and then compacted with two passes of a 500 lbs. roller. Yielding material deflecting more than ½-inch under the specified roller shall be removed to a depth equal to the thickness of pavement indicated on plans and replaced with an approved granular material which shall then be compacted as described above. The complete subgrade shall be tested for grade and cross section with a template extending the full width of the sidewalk and supported between side forms. The subgrade shall be maintained in a smooth, compacted condition, in conformity with the required section and established grade until the concrete is placed. The subgrade shall be in a moist condition when the concrete is placed. In cold weather, the subgrade shall be prepared and protected as to provide a subgrade free from frost when the concrete is deposited.

3.3 GRAVEL BASE COURSE:

- A. Gravel base shall be of thickness indicated on detail.

3.4 FORMS:

- A. Forms shall be of wood or steel, straight, or sufficient strength to resist during depositing and consolidating concrete, and of height equal to the full depth of the finished sidewalk. Wood forms shall be surfaced plank, 2-inches nominal thickness. Steel forms shall be of approved section with a flat top surface. Forms shall be held rigidly in place by stakes placed at intervals not to exceed 4-feet. Forms shall be coated with form oil each time before concrete is placed. Wood forms may, instead, be thoroughly wet with water before concrete is placed, except that with probable freezing temperatures, oiling is mandatory. Side forms shall not be removed for less than 12 hours after finishing has been completed.

3.5 CONCRETE PLACEMENT AND FINISHING:

- A. Concrete shall be placed in the forms in one layer of thickness indicated on plans. After the concrete has been placed in the forms, a strike-off guided by the side forms shall be used to bring the surface to the proper section to be compacted. The concrete shall be tamped and consolidated with a suitable wood or metal tamping bar, and the surface shall

be finished to grade with wood float. The finished surface of the walk shall not vary more than 3/16-inch from the testing edge of a 10-foot straight edge. Irregularities exceeding the above shall be satisfactorily corrected. The surface shall be divided into rectangular or square areas by means of control joints.

3.6 CONTROL JOINTS:

- A. The control joints shall be formed in the fresh concrete by cutting a groove in the top portion of the slab to a depth of at least one-fifth of the sidewalk slab thickness, using a jointer to cut the groove, or by sawing a groove in the hardened concrete with a power driven saw. Any membrane-cured surface damaged during the sawing operations shall be re-sprayed as soon as the surface become dry.
- B. Unless otherwise specified, control joints shall occur at the same dimension as the width of walk.

3.7 ISOLATION JOINTS:

- A. Unless otherwise specified, isolation joints shall occur at the following locations.
 - 1. Between walk and curb.
 - 2. Intersections of walk.
 - 3. Between walk and building walls.
 - 4. Between walk and all structure (i.e., walls and planters).
 - 5. On continuous walks, isolation joints shall be a minimum of 40-feet apart.
- B. Isolation joints shall be installed at sidewalk intersections and opposite isolation joints in adjoining curbs. Where the sidewalk is not in contact with the curb, isolation joints shall be installed as indicated. Expansion joints shall be filled with 1/2-inch thick joint filler strips conforming to ASTM D 1751. Joint filler shall be placed with top edge 1/4-inch below the surface and shall be held in place with steel pins or other devices to prevent warping of the filler during floating and finishing. Immediately after finishing operations are completed, joint edges shall be rounded with the edging tool having a radius of 1/4-inch, and concrete over the joint filler shall be removed. Expansion joints shall be formed about structures and features that project through or into sidewalk pavement, using joint filler of the type, thickness, and width indicated. The filler shall be installed in such a manner as to form a complete, uniform separation between the structure and sidewalk pavement. At the end of the curing period, expansion joints shall be carefully cleaned and filled with joint sealer conforming to ASTM D 1850. The concrete at the joint sealer shall conform to ASTM D 1850. The concrete at the joint shall be surface dry, and the atmospheric and pavement temperatures shall be above 50°F at the time of application of joint-sealing materials. The joints shall be filled flush with the concrete surface in such a manner as to minimize spilling on the walk surface. Spilled sealing material shall be removed immediately and the surface of the walk cleaned. Dummy groove joints (decorative line scoring) shall not be sealed.
- C. Unless otherwise specified, decorative line scoring shall occur every 4-linear feet.

3.8 SURFACE UNIFORMITY:

- A. The completed surface shall be uniform in color and free of surface blemishes and tool marks.

3.9 CURING:

- A. Immediately after the finishing operations, the exposed concrete surface shall be cured by preventing the loss of moisture for seven days by the mat, impervious-sheet or membrane-curing method.

3.10 BACKFILLING:

- A. After curing, debris shall be removed, and the area adjoining the sidewalk shall be backfilled, graded and compacted to conform to the surrounding area in accordance with the lines and grades indicated.

END OF SECTION

**SECTION III
DETAILS**



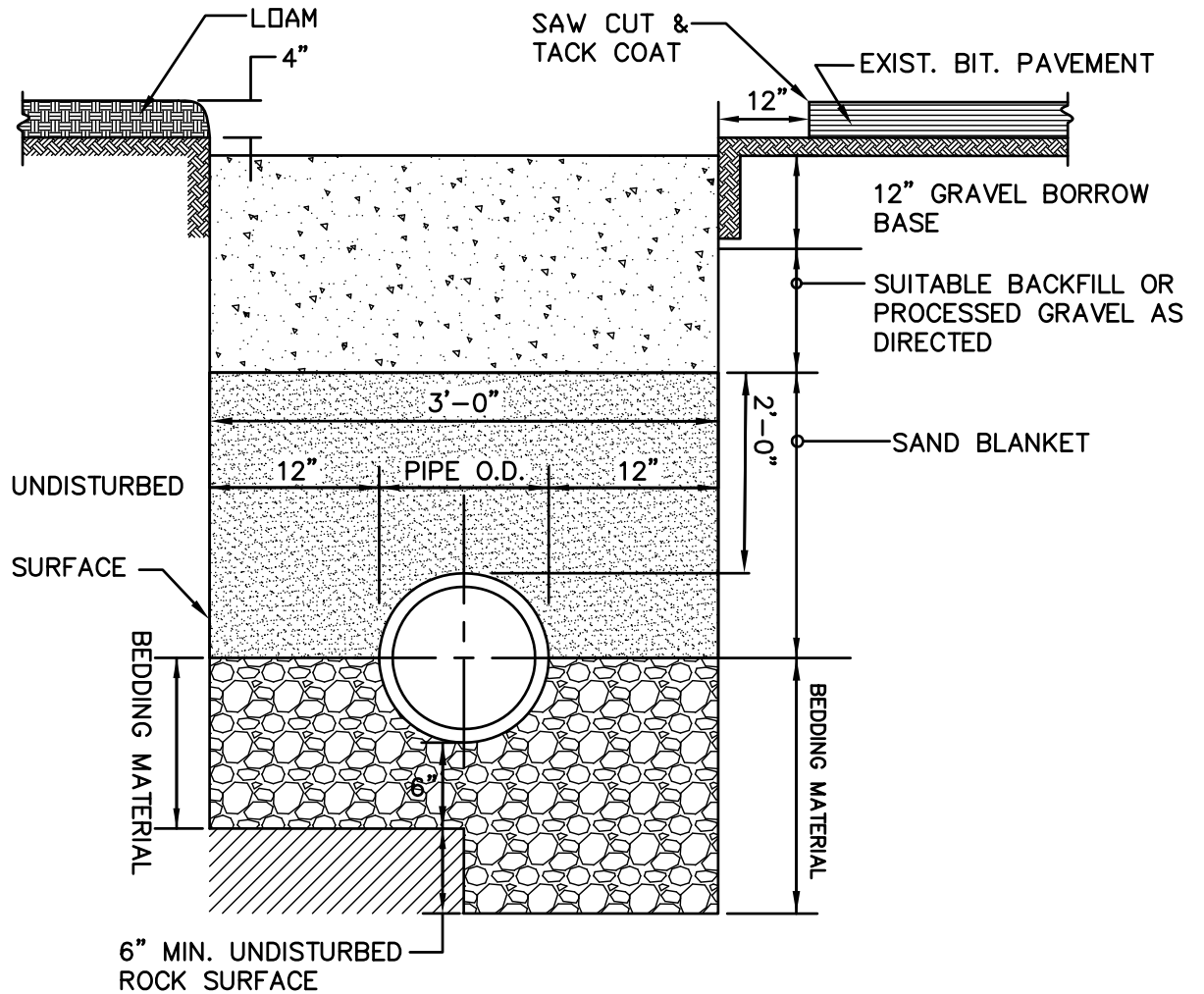

- NOTE:
1. MINIMUM DEPTH OF COVER SHALL BE 4'-0"
 2. PAVEMENT RESTORATION SHALL CONFORM TO THE DEPARTMENT OF PUBLIC WORKS REQUIREMENTS



Town of North Smithfield
Rhode Island

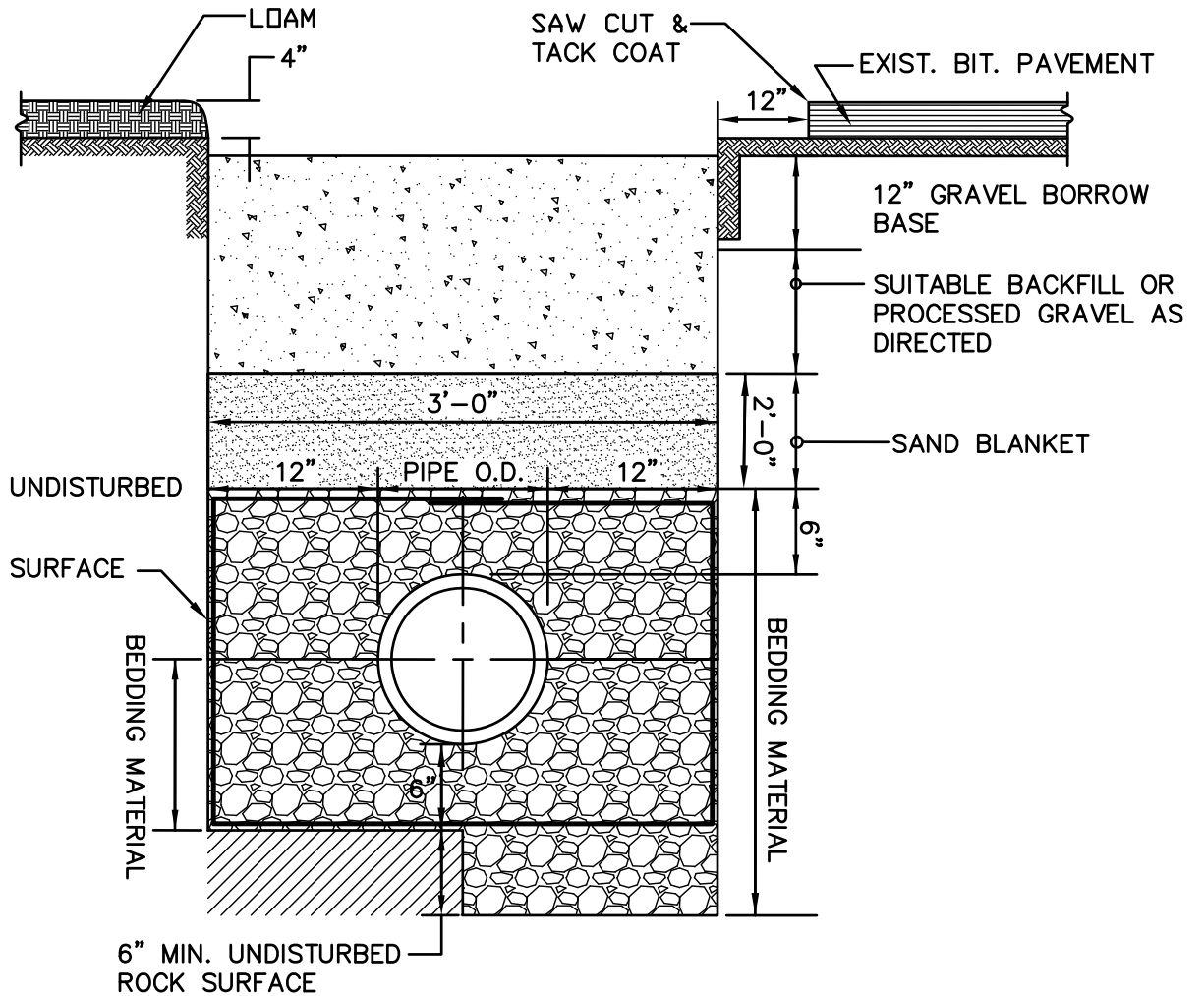

Figure NS-1
TRENCH DETAIL

Standard Sanitary Sewer Requirements

Date: 2009

Scale: No Scale



- NOTE:
1. MINIMUM DEPTH OF COVER SHALL BE 4'-0"
 2. PAVEMENT RESTORATION SHALL CONFORM TO THE DEPARTMENT OF PUBLIC WORKS REQUIREMENTS



Town of North Smithfield
Rhode Island

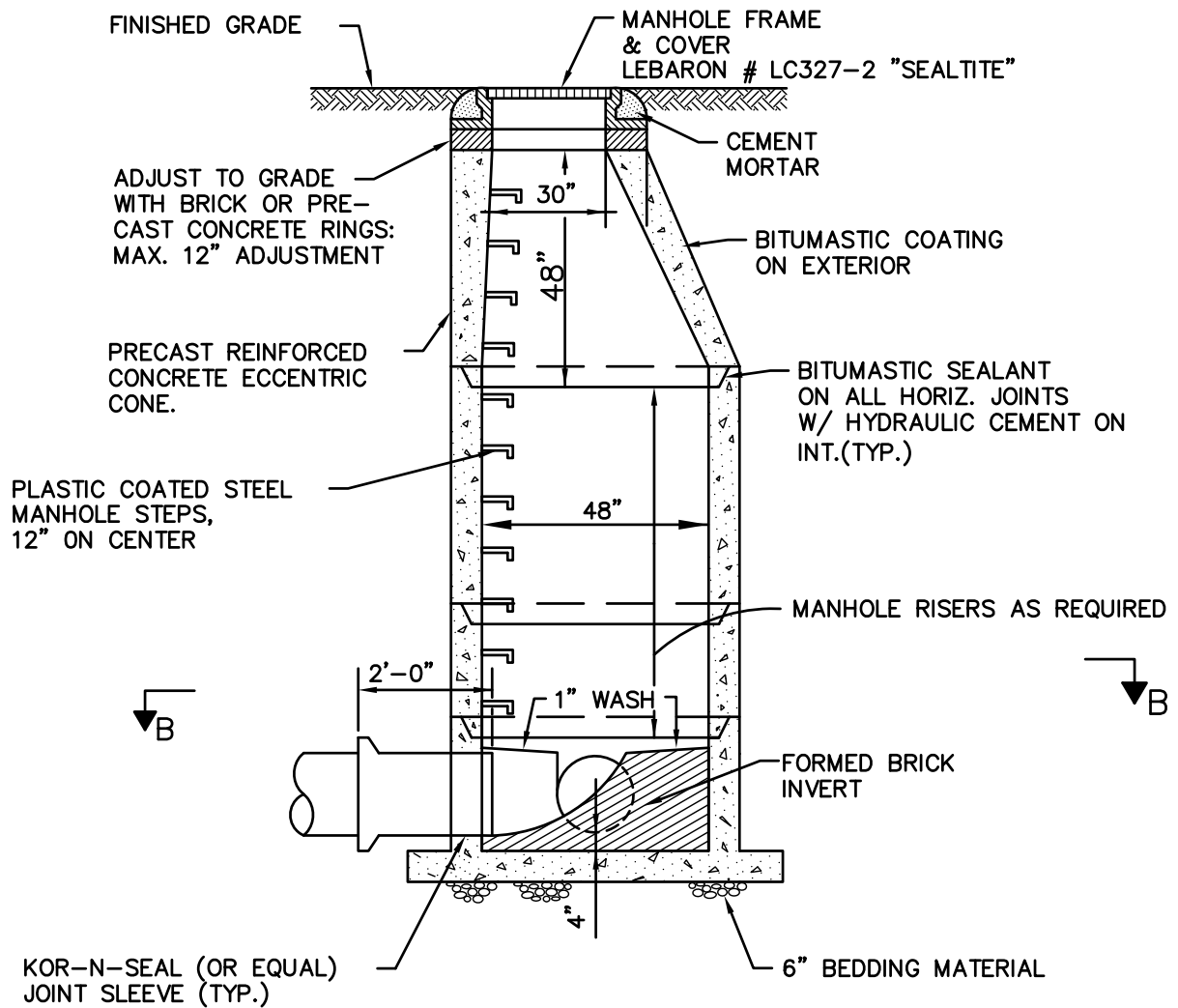

Figure NS-2
TRENCH DETAILS WET CONDITIONS

Standard Sanitary Sewer Requirements

Date: 2009

Scale: No Scale



NOTE: ALL LIFTING HOLES TO BE PLUGGED IN AND OUT WITH HYDRAULIC CEMENT.



Town of North Smithfield
Rhode Island

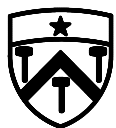
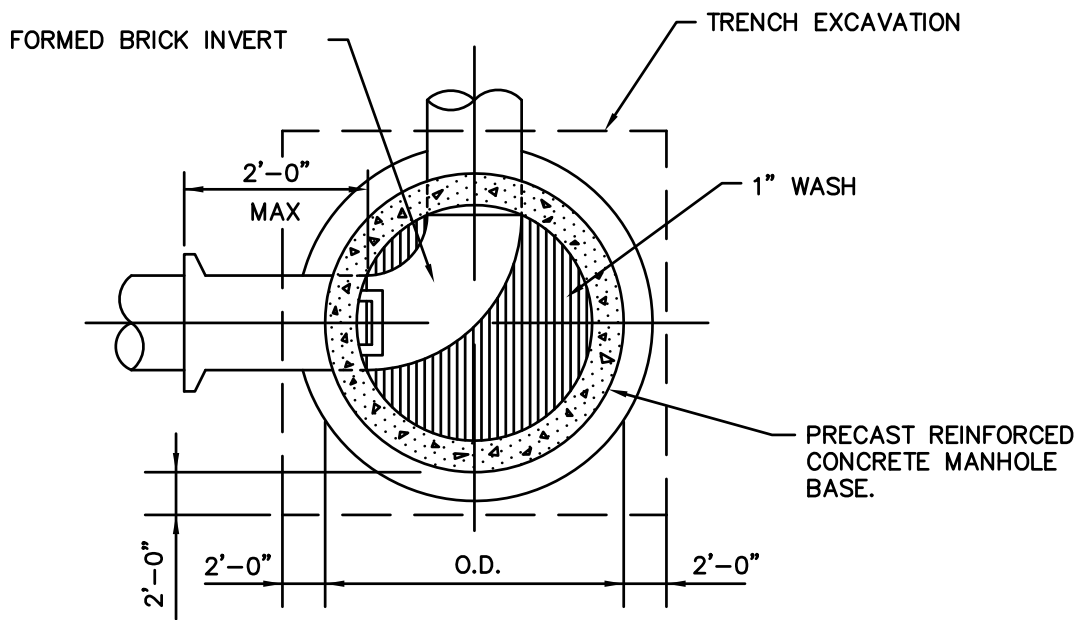

Figure NS-3
SEWER MANHOLE DETAIL

Standard Sanitary Sewer Requirements

Date: 2009

Scale: No Scale



Town of North Smithfield
Rhode Island

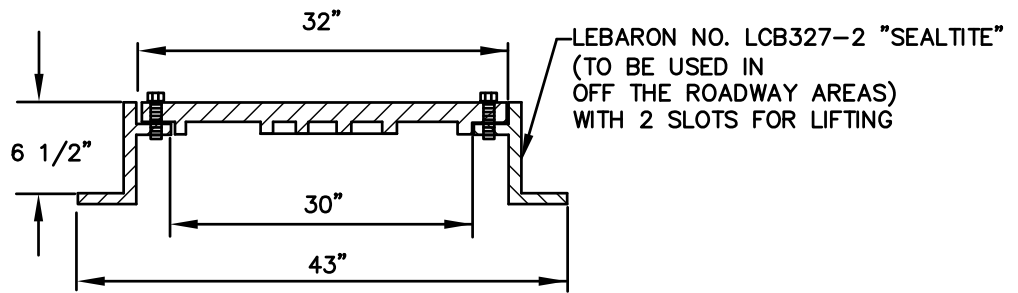
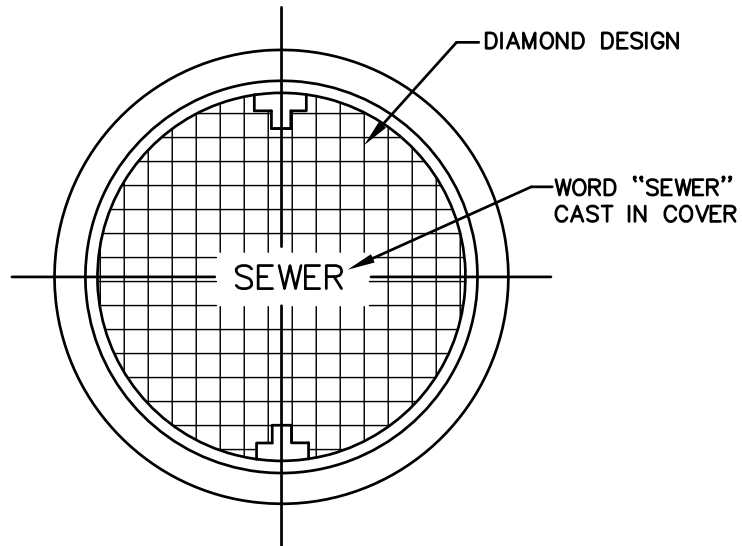

Figure NS-4
PRECAST MANHOLE DETAIL

Standard Sanitary Sewer Requirements

Date: 2009

Scale: No Scale



Town of North Smithfield
Rhode Island

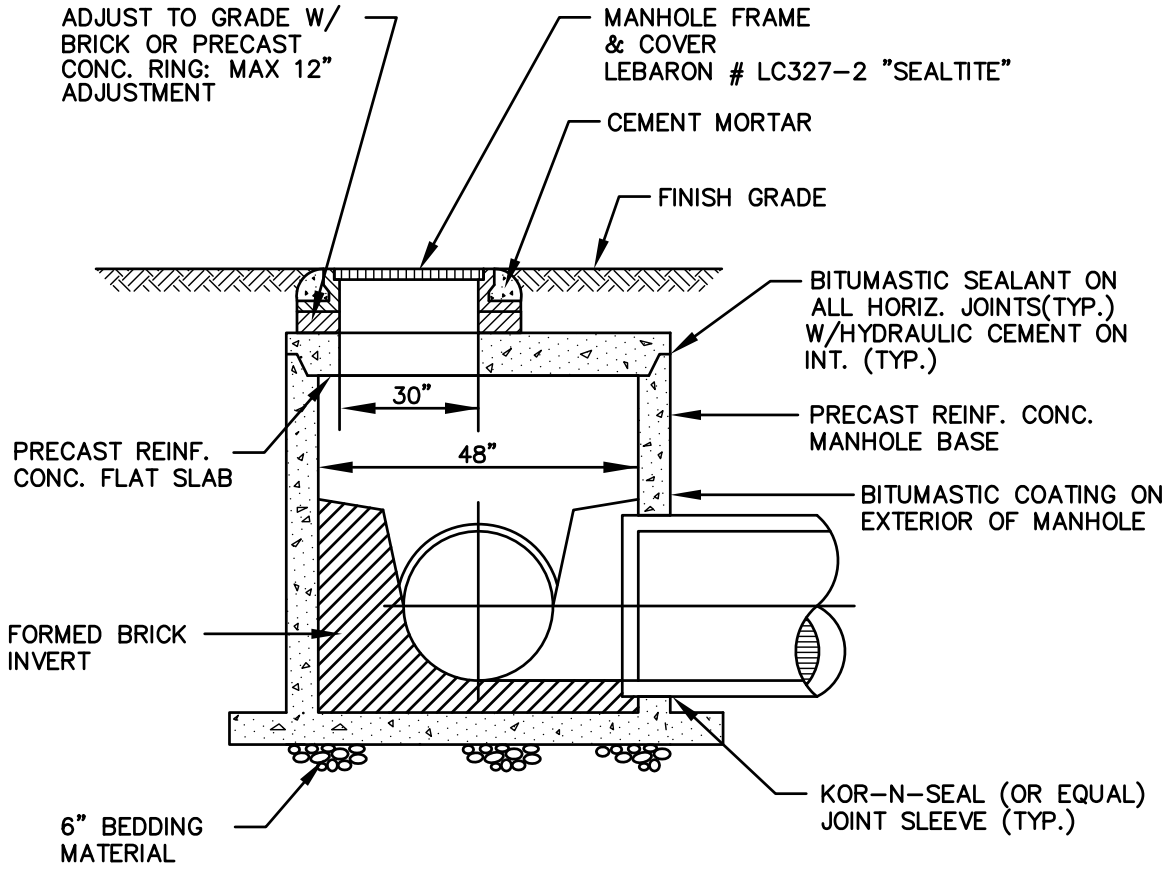

Figure NS-5
BOLTED & GASKETED FRAME & COVER

Standard Sanitary Sewer Requirements

Date: 2009

Scale: No Scale



NOTES: 1. SHALLOW MANHOLES SHALL BE PROVIDED ONLY WHERE THE VERTICAL HEIGHT OF THE MANHOLE IS LESS THAN 6 FEET.

2. ALL LIFTING HOLES TO BE PLUGGED IN AND OUT WITH HYDRAULIC CEMENT.



Town of North Smithfield
Rhode Island

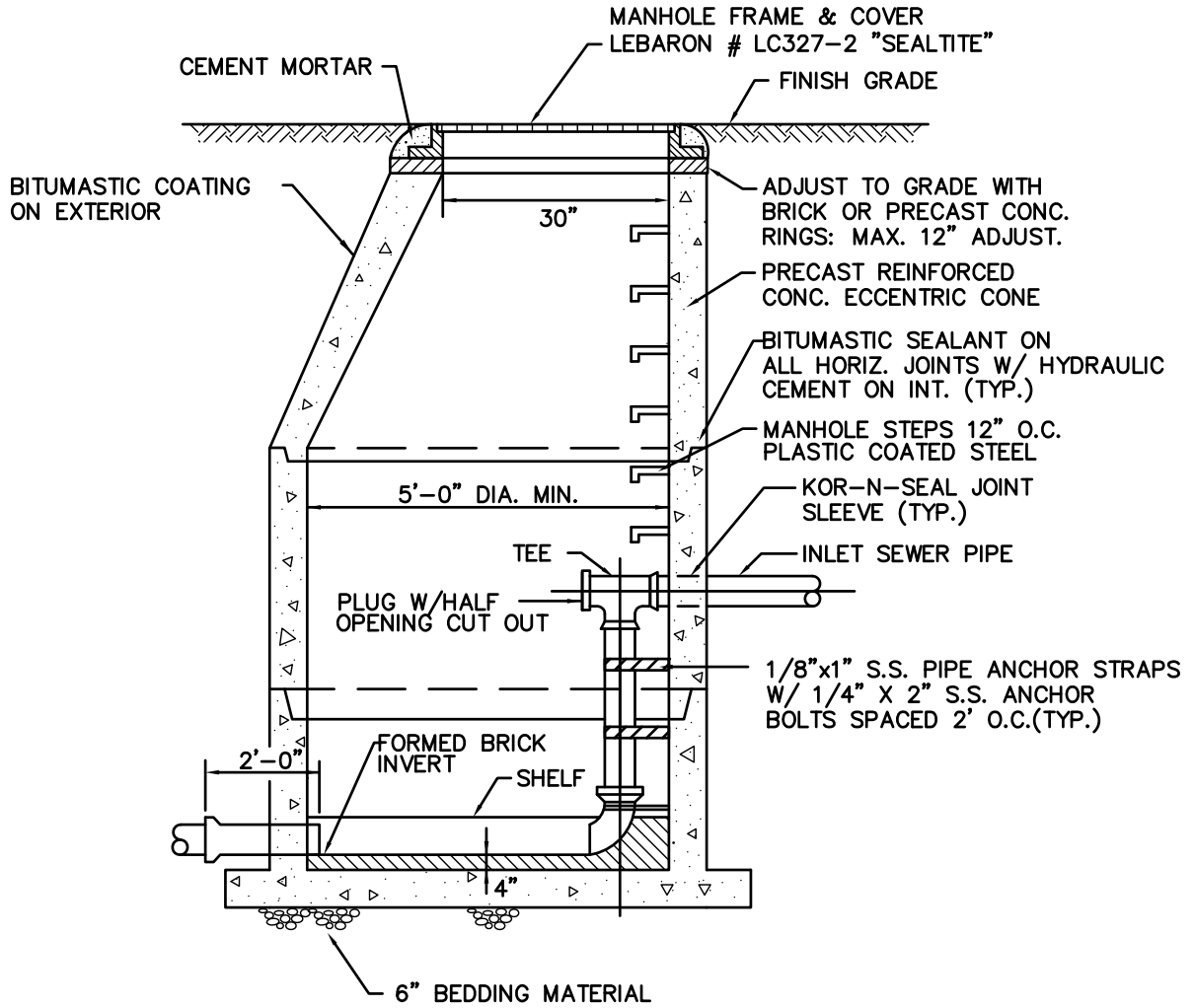

Figure NS-6
SANITARY SHALLOW MANHOLE DETAIL

Standard Sanitary Sewer Requirements

Date: 2009

Scale: No Scale



NOTE:

1. ALL LIFTING HOLES TO BE PLUGGED IN AND OUT WITH HYDRAULIC CEMENT.
2. DROP PIPE SHALL BE PVC AND SAME SIZE AS INLET SEWER.

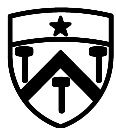

Town of North Smithfield
Rhode Island

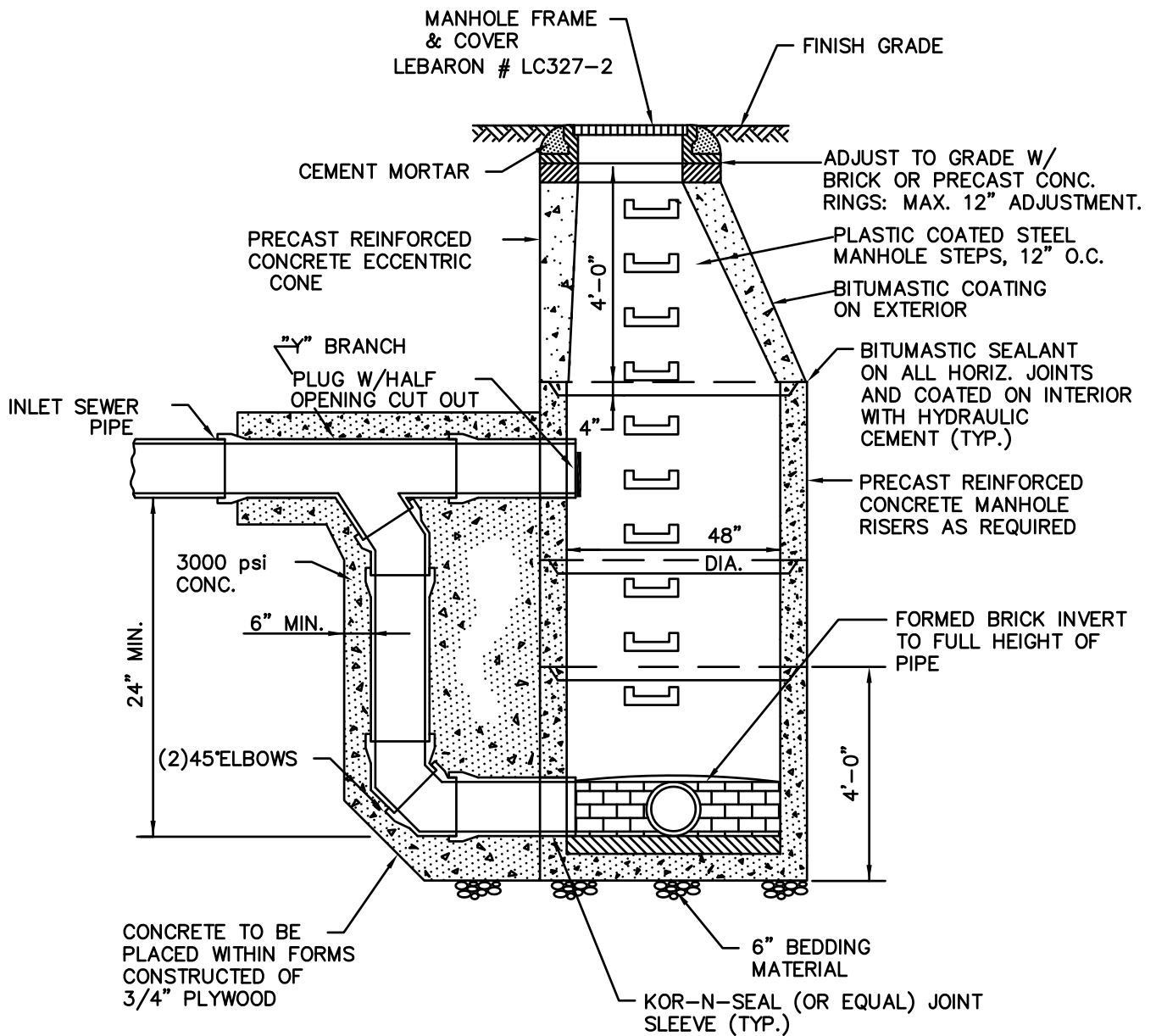

Figure NS-7
INSIDE DROP SANITARY MANHOLE

Standard Sanitary Sewer Requirements

Date: 2009

Scale: No Scale



NOTE:

1. ALL LIFTING HOLES TO BE PLUGGED IN AND OUT WITH HYDRAULIC CEMENT.
2. DROP PIPE SHALL BE PVC AND SAME SIZE AS INLET SEWER.



Town of North Smithfield
Rhode Island

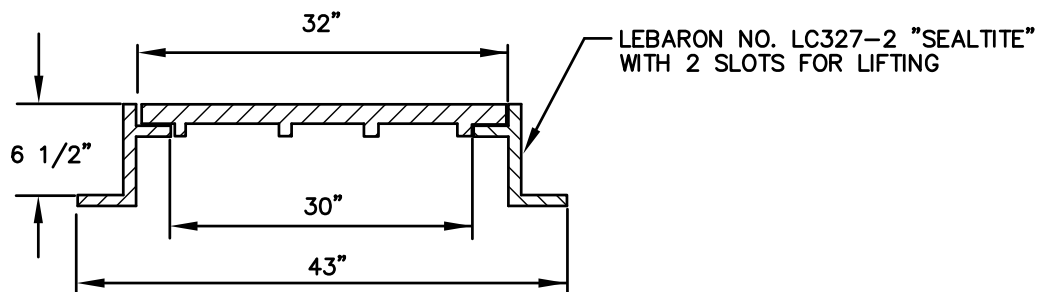
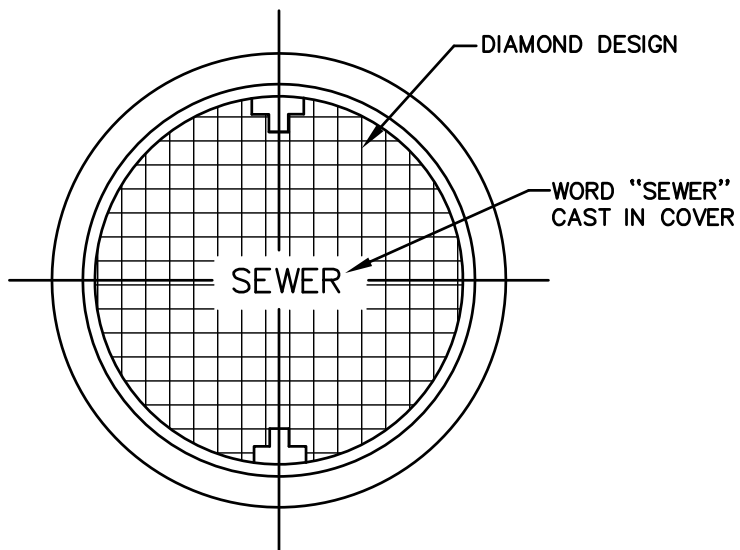

Figure NS-8
EXTERNAL DROP SANITARY MANHOLE

Standard Sanitary Sewer Requirements

Date: 2009

Scale: No Scale



NOTE:
 1. VENTILATION HOLES OF ANY SIZE ARE NOT ALLOWED



Town of North Smithfield
 Rhode Island

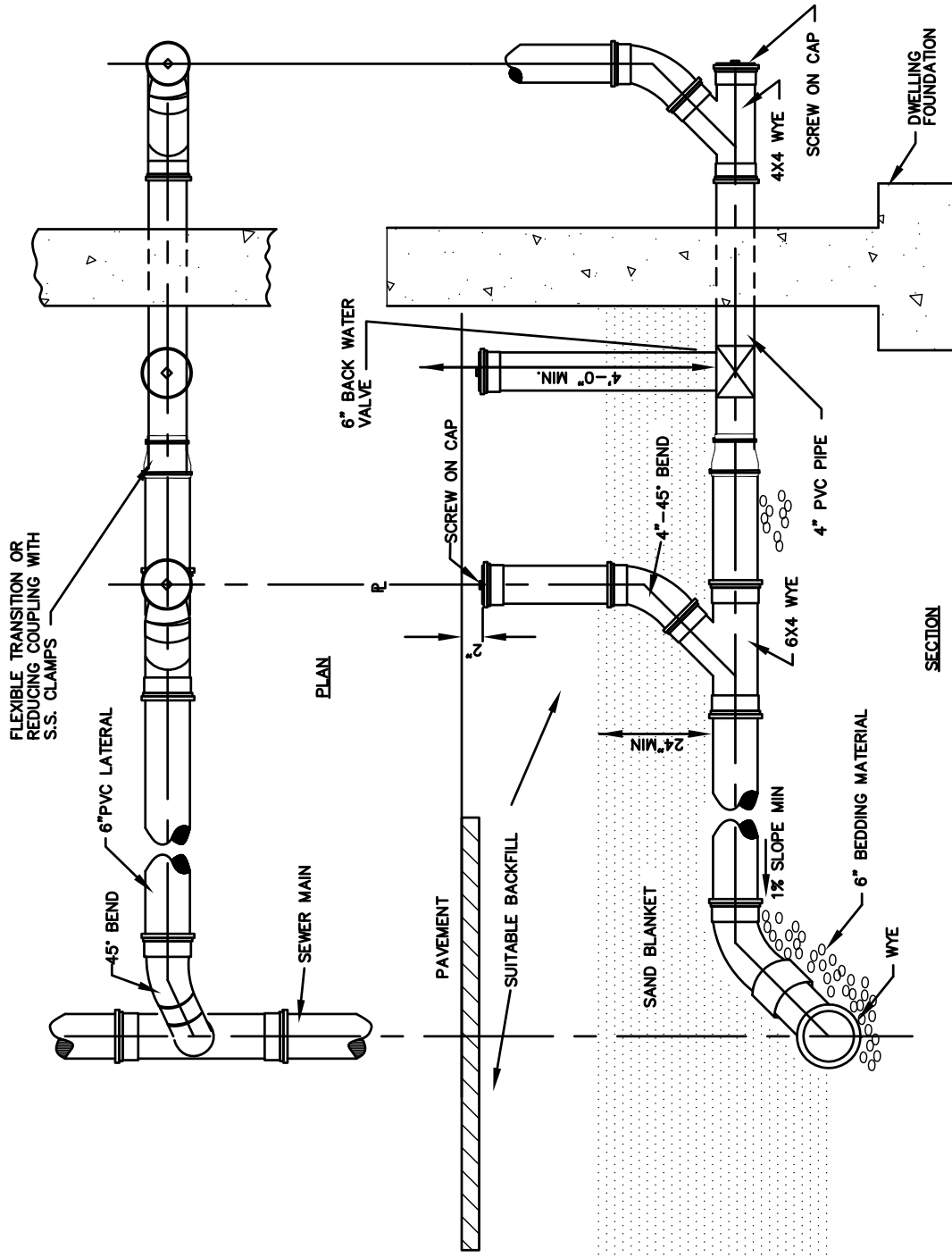

Figure NS-9
 SANITARY MANHOLE FRAME & COVER

Standard Sanitary Sewer Requirements

Date: 2009

Scale: No Scale



NOTE: 1.FOR AN EXISTING SEWER MAIN THAT DOES NOT HAVE A WYE INSTALLED, THE CONTRACTOR SHALL INSTALL A PIPE SADDLE.

Figure NS-10
STANDARD HOUSE CONNECTION DETAIL
 Standard Sanitary Sewer Requirements
 Date: 2009
 Scale: No Scale



Town of North Smithfield
 Rhode Island

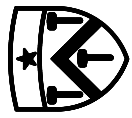

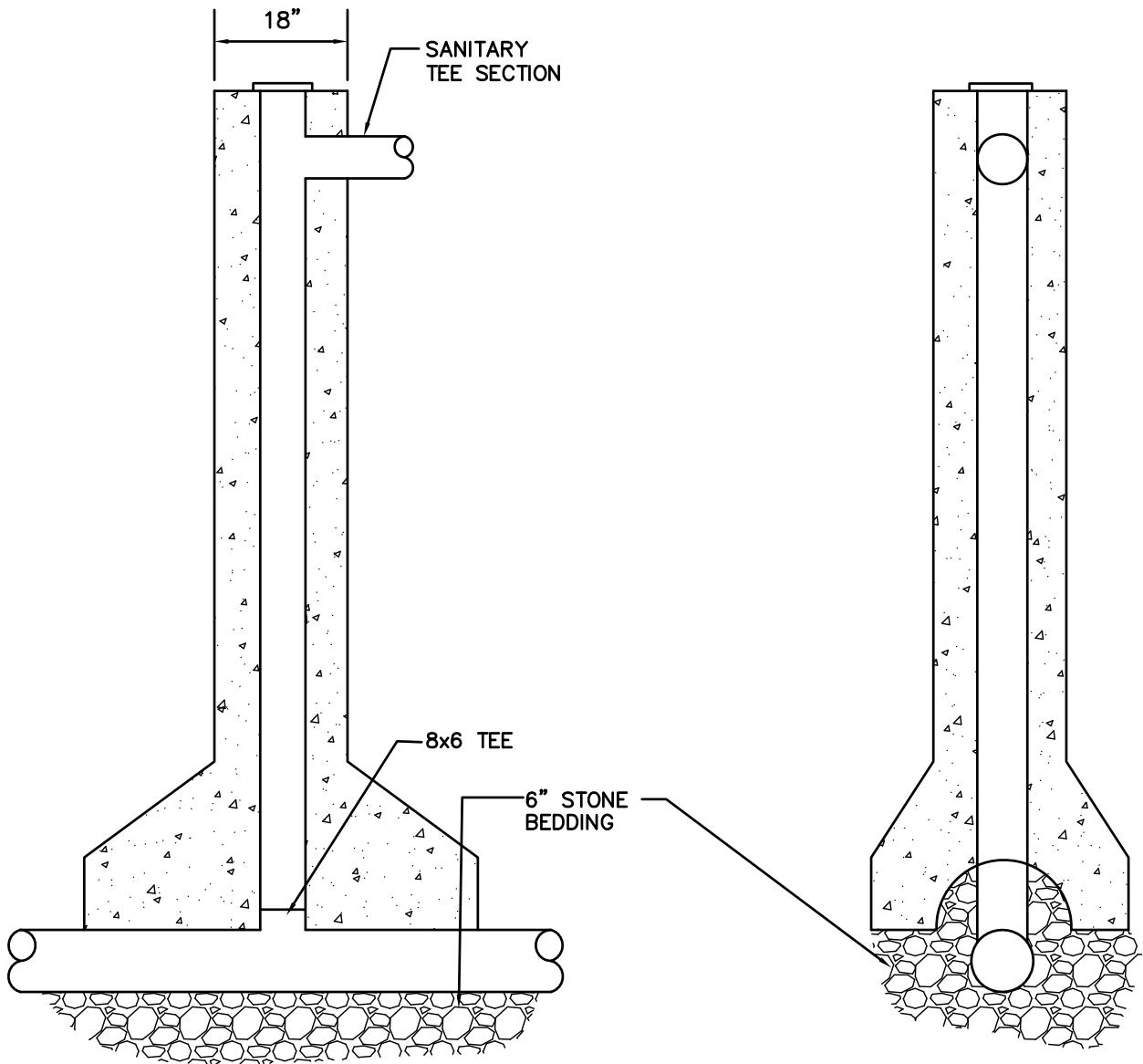

NOTE:
 FOR AN EXISTING SEWER MAIN THAT DOES NOT HAVE A TEE
 INSTALLED, THE CONTRACTOR SHALL INSTALL A TEE.



Town of North Smithfield
 Rhode Island

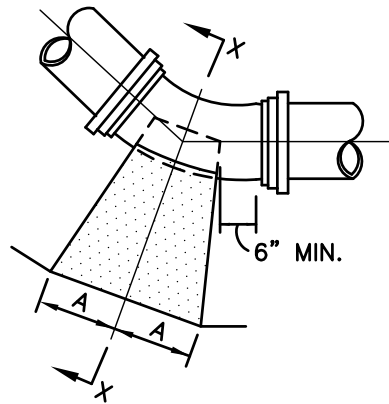

Figure NS-11
 STANDARD DEEP HOUSE CONNECTION

Standard Sanitary Sewer Requirements

Date: 2009

Scale: No Scale



PLAN BENDS

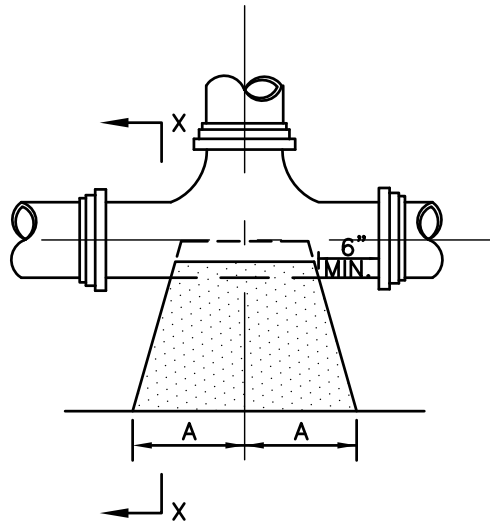

PLAN TEES

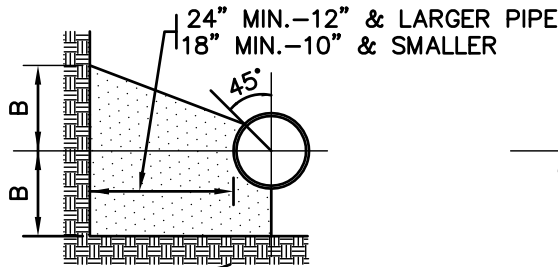

SECTION X-X BENDS & TEES

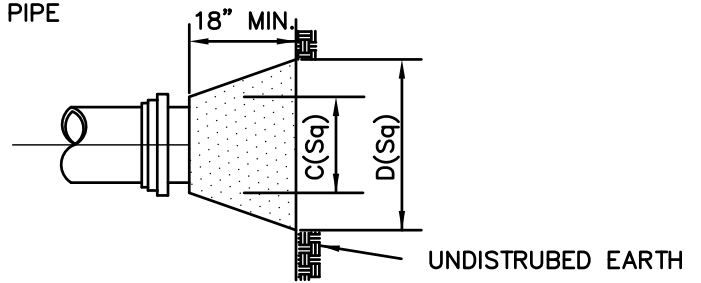

PLAN & ELEVATION PLUGS

UNDISTRUBED EARTH

UNDISTRUBED EARTH

TYPE	SIZE	1/4 BENDS		1/8 BENDS		1/16 BENDS		TEES		PLUGS	
		A	B	A	B	A	B	A	B	C	D
TYPE 1 4000 PSF SOIL	6"	5"	10"	6"	8"	3"	8"	8"	8"	10"	15"
	8"	12"	12"	8"	10"	5"	9"	9"	12"	12"	20"
	10"	16"	14"	10"	12"	6"	10"	11"	14"	14"	25"
	12"	19"	16"	12"	14"	8"	11"	14"	16"	16"	30"
	14"	23"	18"	14"	16"	10"	12"	16"	18"	18"	34"
16"	26"	20"	16"	18"	11"	13"	18"	20"	20"	38"	
TYPE 2 2000 PSF SOIL	6"	16"	10"	9"	10"	6"	8"	10"	12"	10"	21"
	8"	22"	13"	12"	13"	8"	10"	13"	16"	12"	29"
	10"	26"	17"	14"	17"	10"	13"	16"	20"	14"	36"
	12"	29"	21"	16"	21"	11"	16"	18"	24"	16"	41"
	14"	35"	24"	19"	24"	12"	20"	22"	27"	18"	48"
16"	38"	27"	21"	27"	12"	24"	24"	30"	20"	54"	



Town of North Smithfield
Rhode Island

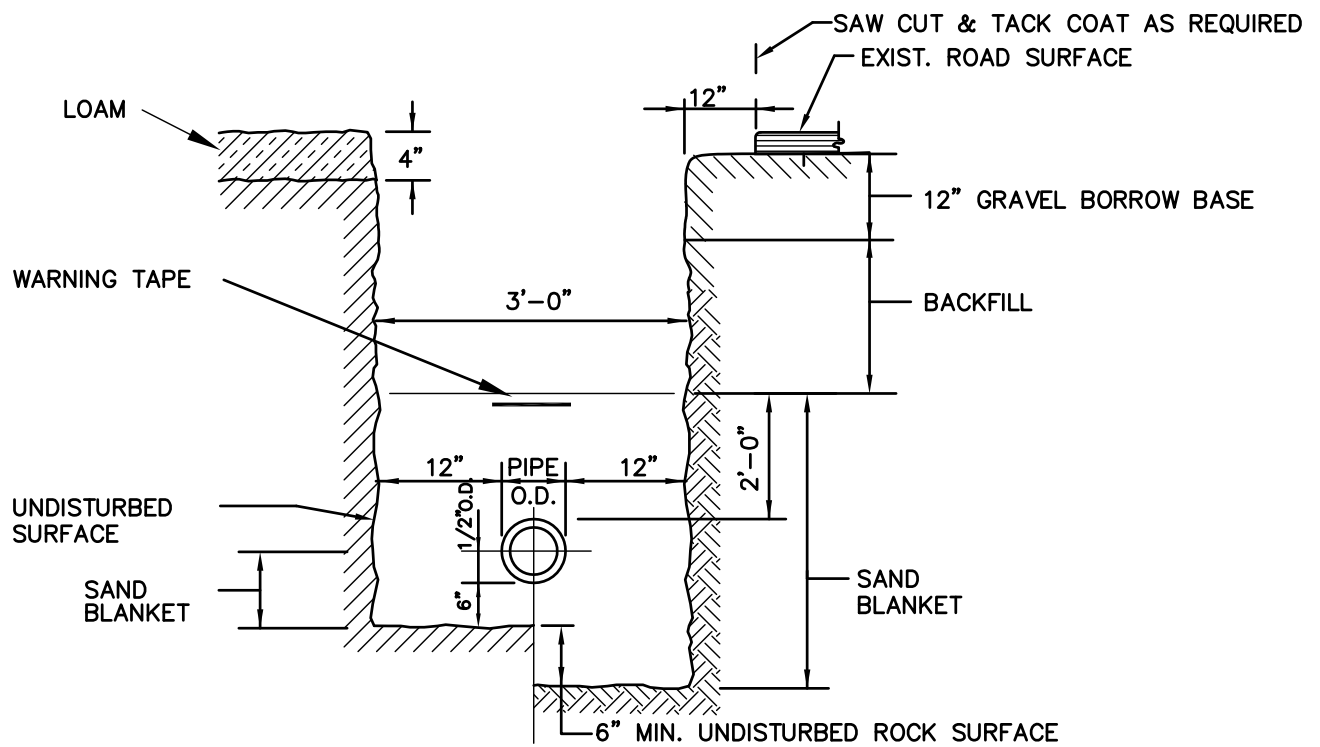

Figure NS-12
THRUST BLOCKS

Standard Sanitary Sewer Requirements

Date: 2009

Scale: No Scale



NOTE:

1. MINIMUM DEPTH OF COVER SHALL BE 4'-0"
2. WHEN IN GROUNDWATER SEE DETAIL NS-2
3. PAVEMENT RESTORATION SHALL CONFORM TO THE DEPARTMENT OF PUBLIC WORKS REQUIREMENTS



Town of North Smithfield
Rhode Island



Figure NS-13
LOW PRESSURE SEWER TRENCH

Standard Sanitary Sewer Requirements

Date: 2009

Scale: No Scale

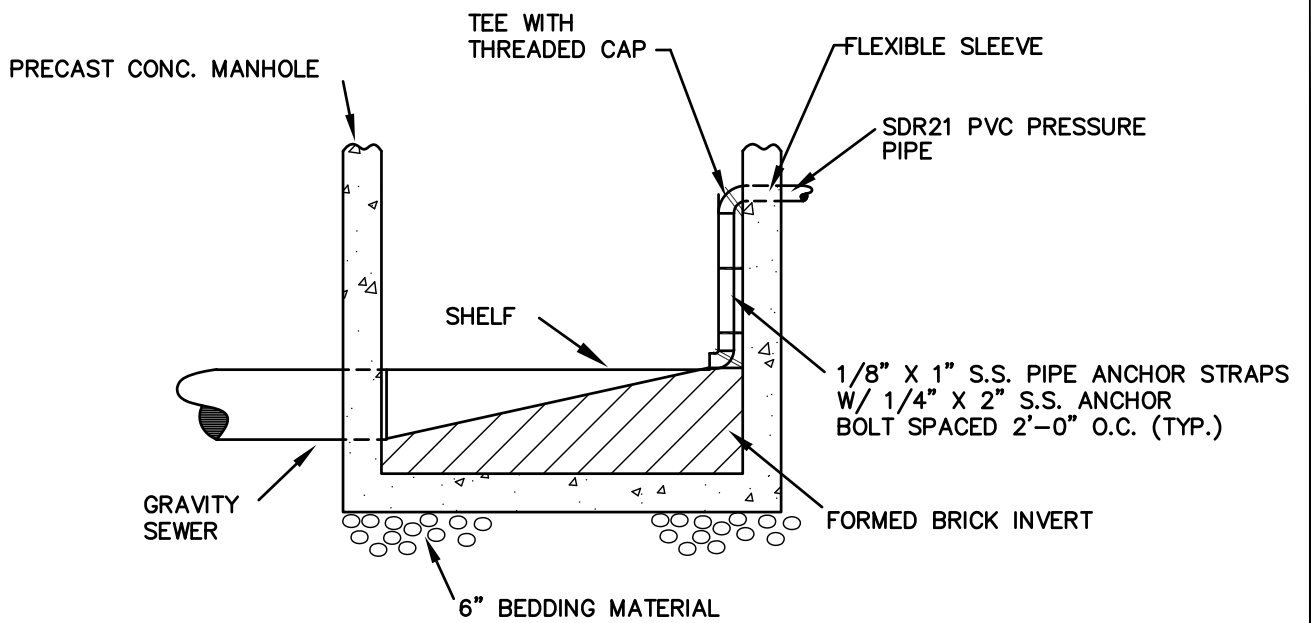
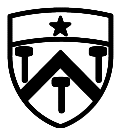

Figure NS-14
 LOW PRESSURE SEWER INSIDE DROP MANHOLE



Town of North Smithfield
 Rhode Island



Standard Sanitary Sewer Requirements

Date: 2009

Scale: No Scale

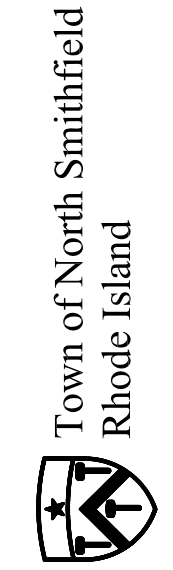
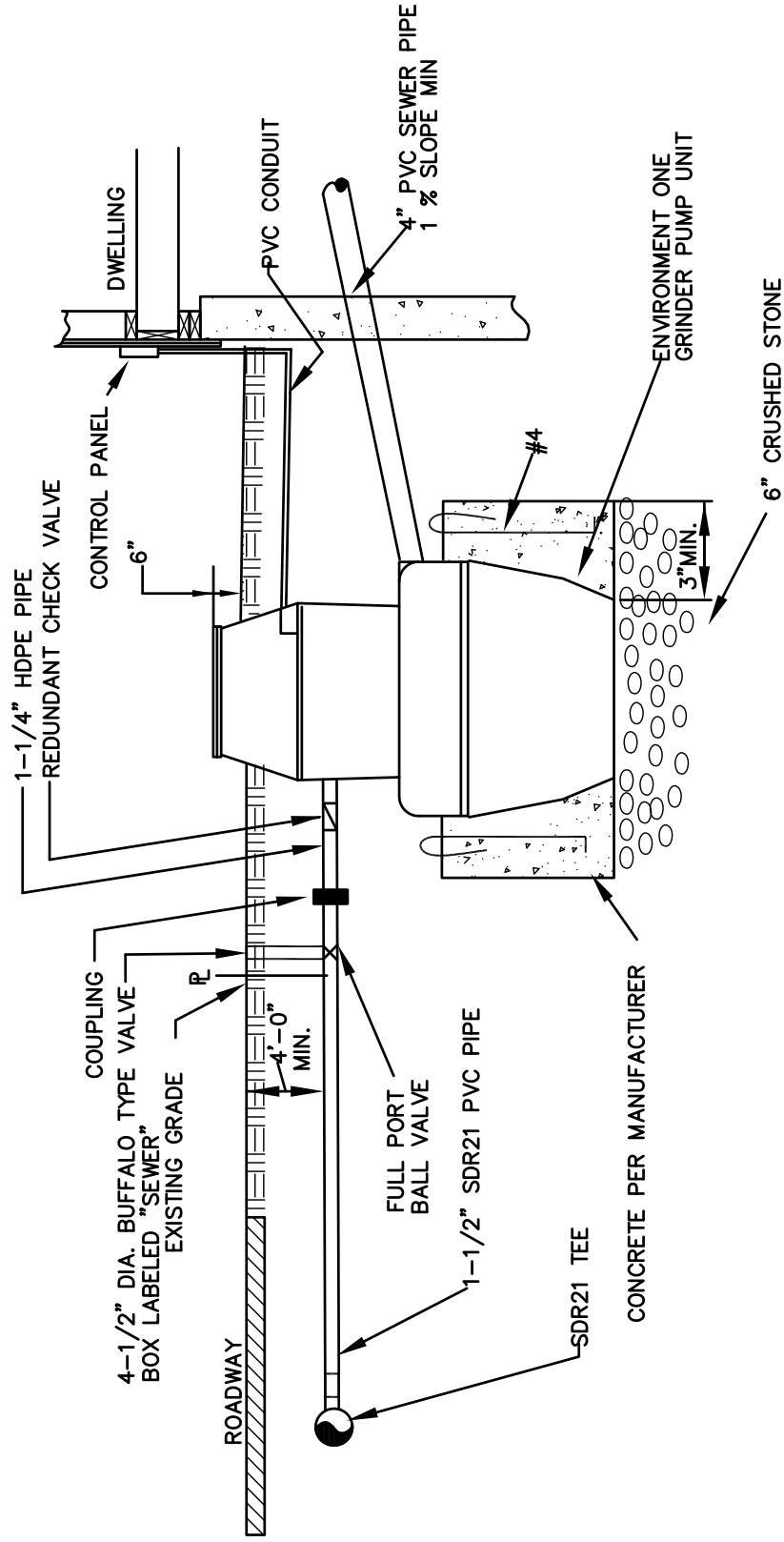

Town of North Smithfield
 Rhode Island

Figure NS-15
 LOW PRESSURE SEWER SERVICE CONNECTION

Standard Sanitary Sewer Requirements

Date: 2009

Scale: No Scale



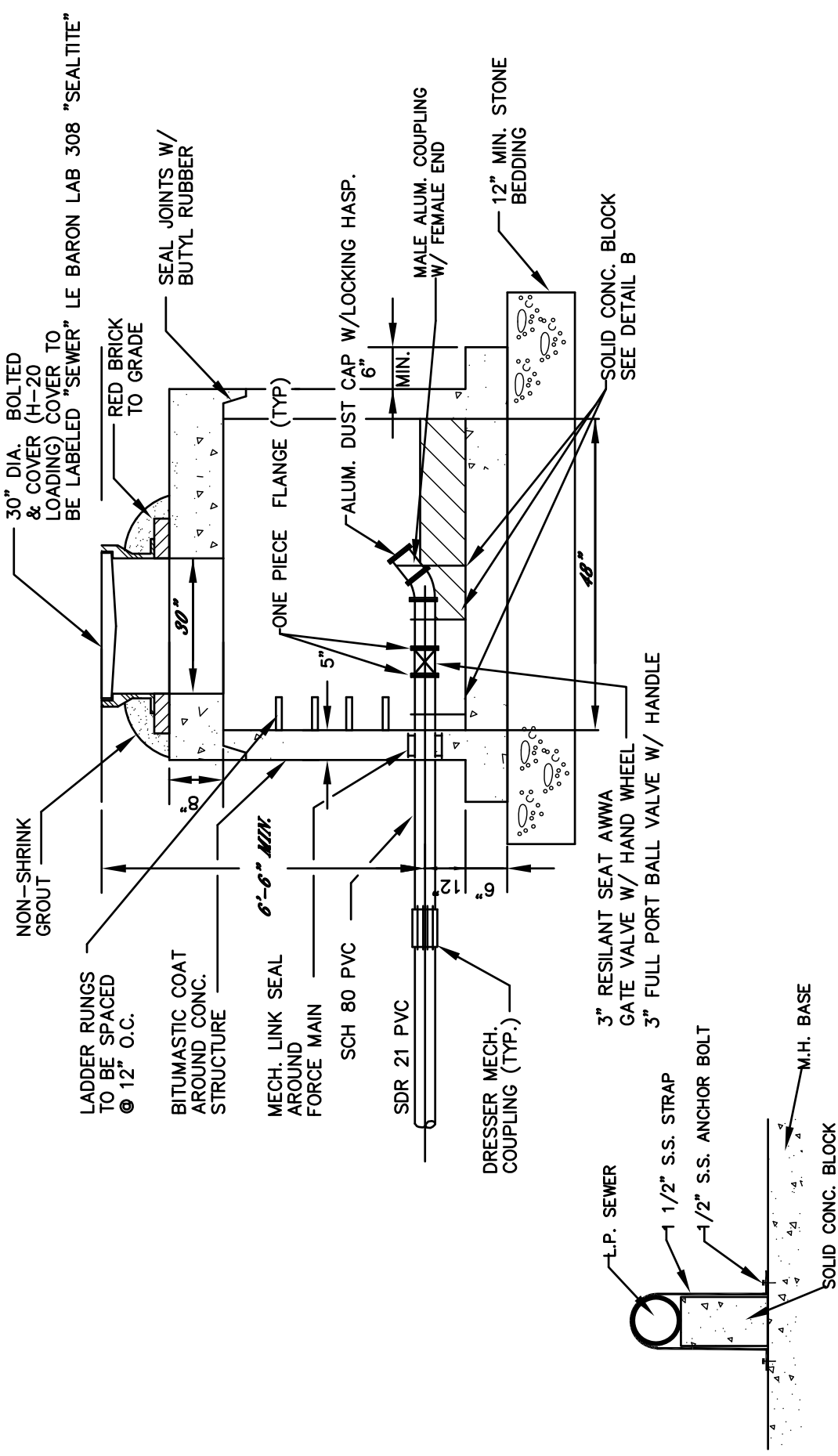

DETAIL "B"

NOT TO SCALE

Town of North Smithfield
Rhode Island

Figure NS-16
LOW PRESSURE TERMINAL END FLUSHING CONNECTION

Standard Sanitary Sewer Requirements

Date: 2009

Scale: No Scale

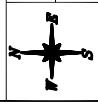

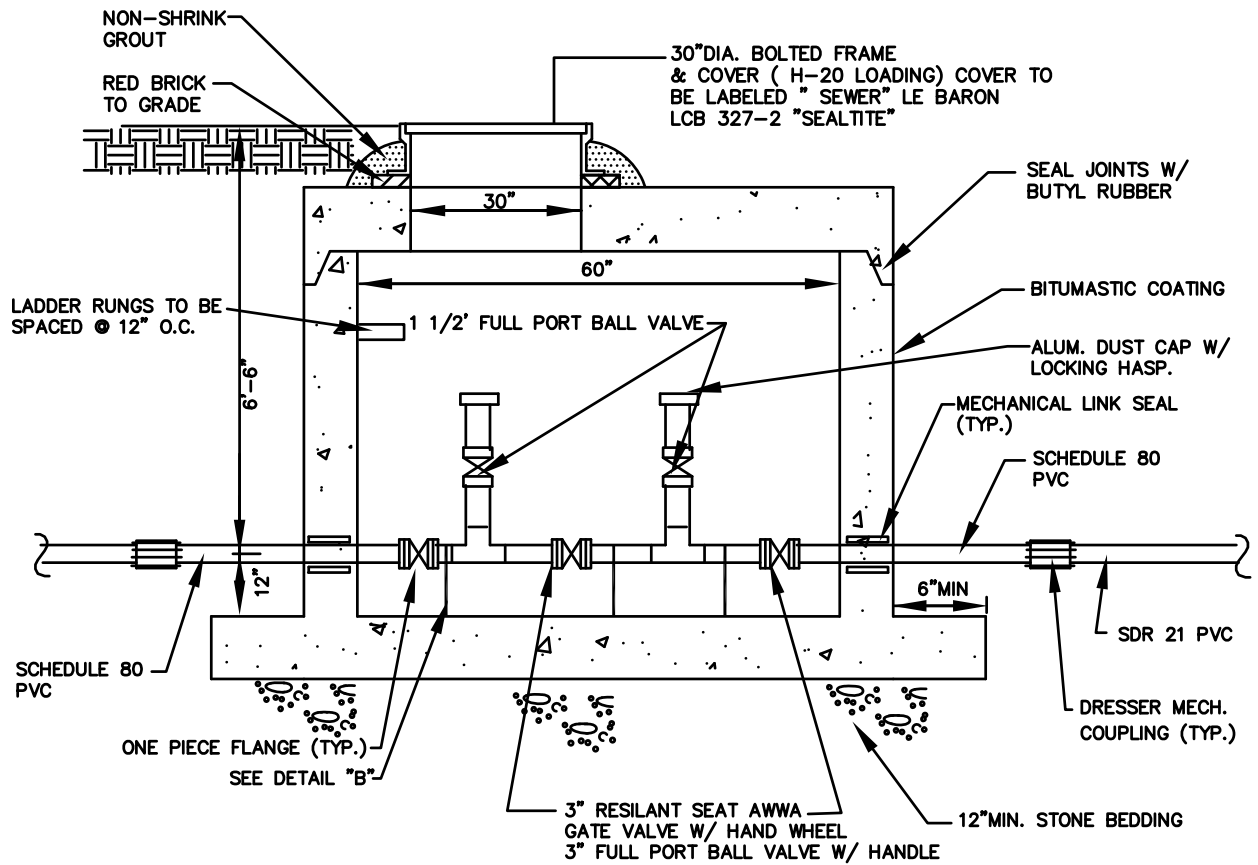

**SECTION
IN LINE FLUSHING CONNECTION**

NOT TO SCALE

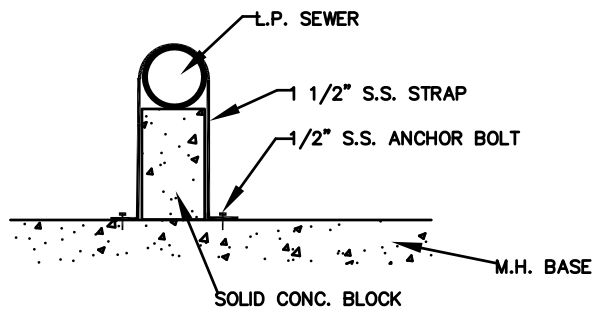

DETAIL "B"

NOT TO SCALE

Figure NS-17
LOW PRESSURE IN-LINE STRAIGHT
THROUGH FLUSHING CONNECTION

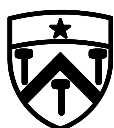

Town of North Smithfield
Rhode Island



Standard Sanitary Sewer Requirements

Date: 2009

Scale: No Scale

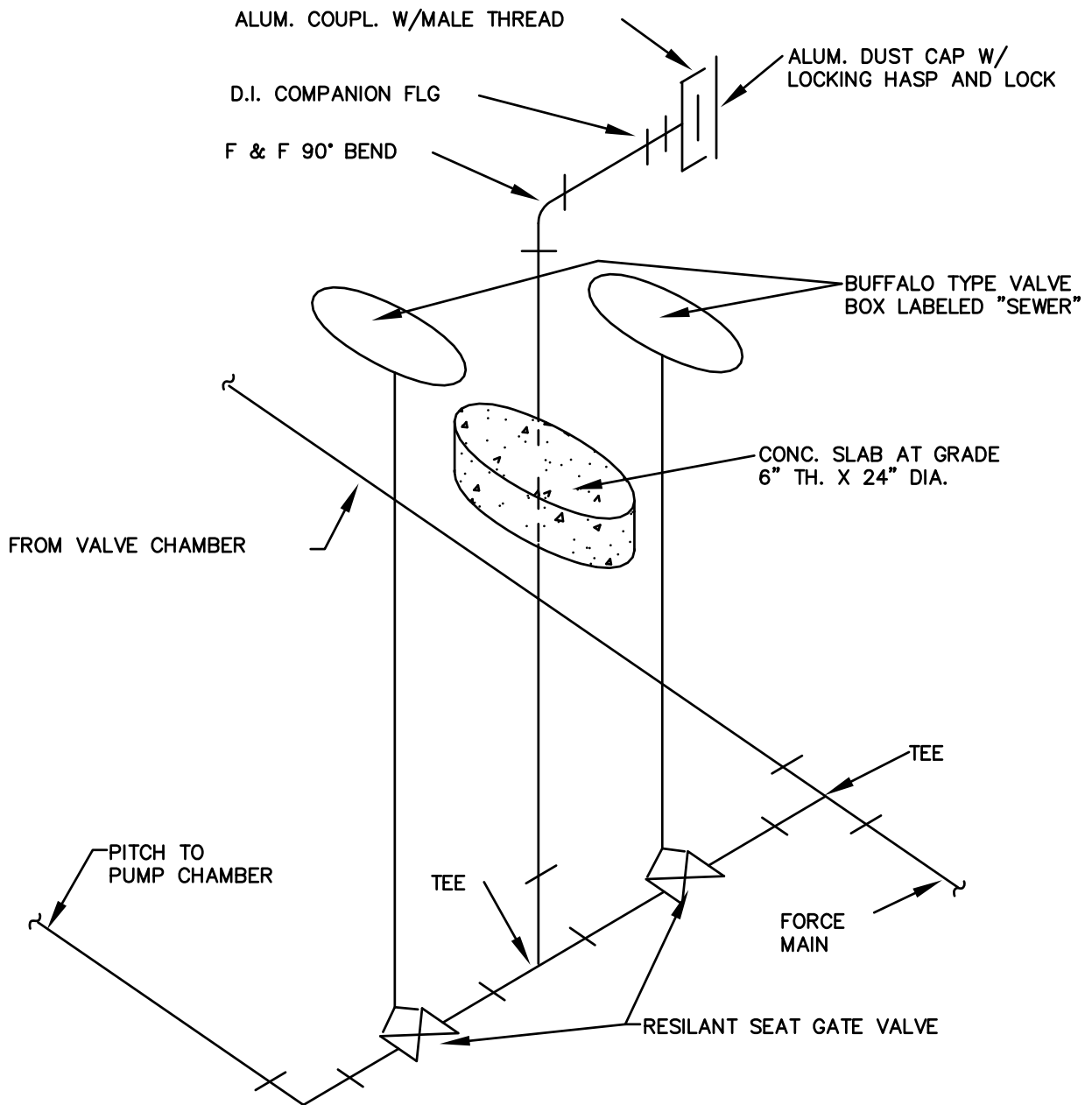

NOTE:
 PROVIDE ONE VALVE KEY



Town of North Smithfield
 Rhode Island

Figure NS-19
 BYPASS PUMPING CONNECTION AT PUMP STATION



Standard Sanitary Sewer Requirements

Date: 2009

Scale: No Scale